

**BIDDING DOCUMENT FOR PROCUREMENT OF SCHOOL DESK TO
PRIMARY SCHOOLS AT BAHU AND CHAMWINO DISTRICT, DODOMA
REGION**

GOOD NEIGHBORS TANZANIA

P.O. BOX 33104

DAR ES SALAAM

EMAIL: gntzHO@goodneighbors.or.tz

GOOD NEIGHBORS TANZANIA

INVITATION FOR BID (IFB)

Bid No. GNTZ/HO/007/2024

FOR

PROCUREMENT OF SCHOOL DESK TO PRIMARY SCHOOLS AT BAHU AND CHAMWINO DISTRICT, DODOMA REGION.

1. Good Neighbors Tanzania (GNTZ) Invites interested bidders for the Procurement of School Desks to Primary Schools at Bahu and Chamwino District, Dodoma Region.
2. Good Neighbors Tanzania (GNTZ) invites sealed bids from eligible suppliers who meet the requirements to school desks (Wooden) to respective areas.
3. Bidders may request a clarification of bidding document only up to Five (5) days before the Bid submission deadline at the office of Good Neighbors-Tanzania Head Office, Plot No. 2047, Block 'K', Boko Chama, Dar es Salaam from 08:00 AM to 04:00 PM, Monday to Thursday, except on Public Holidays.
4. Tenders should be delivered direct (hand delivery) to our office located in Dar es Salaam, along Bagamoyo road, Boko area, near Chama before **10:00AM, 24th July, 2024**. Tenders shall be opened thereafter at the same address in the presence of the bidders.
5. This advert for this tender is also available to Good Neighbors Tanzania website: www.goodneighbors.or.tz
6. Bidders who operate within Dodoma Region are highly encouraged to apply.

BID DATA SHEET (BDS)

Part of the Instructions to Suppliers used to reflect specific terms and assignment conditions.

Procurement Details	<p>The subject is to procure school desks for Primary Schools at Bahi and Chamwino District, Dodoma Region.</p> <p>The school desks will be delivered to Ilewelo Primary School, Sasajila Primary School, Nagulo Bahi Primary School and Uhelela Primary School as per specifications to Schedule of Requirements and Drawings.</p>
Period of Service	<p>Period for supply of goods is within 30 days after Contract signing or issue of Local Purchase Order.</p>
Tender Validity Period	<p>Bids remain Valid for 90 days after submission date.</p>
Language of Tender	<p>The Tender prepared by the Tenderer, as well as all correspondence and documents relating to the Tender exchanged by the Tenderer and Good Neighbors Tanzania shall be written in the English language.</p>
Preparation and Instruction to Bid Submission	<p>The bidder shall seal the two envelopes (both Technical and Financial bids in two separate envelopes). One envelope marked as “Technical bid” and another envelope marked as “Financial Bid”. The two envelopes should be put in one outer cover marked “Tender No. GNTZ/HO/007/2024 Procurement of School Desks to Primary Schools at Bahi and Chamwino District, Dodoma Region.”</p> <p>NB: Submitted tenders will not be considered for further evaluation when instructions are not followed.</p>
Receipt, and Opening of Tenders	<p>The completed Technical and Financial Bids must be delivered at Good Neighbors Tanzania (Dar es Salaam) on or before the time and date stated. Any bid received after the closing time for submission of bids shall be returned to the respective Supplier unopened.</p> <p>After the deadline for submission of Bids, tender documents shall be opened immediately by the Tender Committee.</p>
Evaluation of Tenders	<p><u>Evaluation of Technical Bids</u></p> <p>The evaluation committee appointed by the GNTZ shall evaluate the technical bids on the basis of their responsiveness to Instruction to bid, applying the evaluation criteria as follows: -</p> <p style="text-align: center;">CRITERIA</p> <p>1. Eligibility of supplier</p> <ul style="list-style-type: none"> ● Company Profile (If available) ● Certificate of Registration/Incorporation ● Business Licence ● TIN and VRN Certificate ● Bank Reference Letter

	<p>*All documents should be up to date and related to the field applied.</p> <p>2. General experiences of Supplier (70 Marks)</p> <ul style="list-style-type: none"> ● Provide at least 3 client list for previous similar assignments (supply of school furniture) with details of Name of Client, Project Name, Year, Value and Contacts (30 Marks) ● Provide at least 3 Contracts or Local Purchase Order of similar assignment (supply of school furniture) (40 Marks). <p>*Past experience submitted should be similar to the tender announced.</p> <p>* The Minimum Technical Score required to Pass: 40 Marks</p> <p><u>Evaluation of Financial Bid</u></p> <p>The financial bid will present quotations or Price for implementing the assignment.</p> <p>Financial Proposal will be evaluated for bidders whose Technical Proposal have secured the minimum qualifying marks.</p> <p>Criteria</p> <ul style="list-style-type: none"> • Financial Score will be determined based on the weighted comparison of the lowest bid price. Weighted score: 30 Marks
Negotiation	<p>Before Contract Signing GNTZ may require Negotiation discussion with the successful bidder relating to the following areas.</p> <ul style="list-style-type: none"> (a) A minor alteration to the technical details of the statement of requirements (b) A minor amendment to the conditions of Contract; (c) Delivery arrangements; (d) Clarifying details that were not apparent or could not be finalised at the time of tendering; or (e) Price.
Notification and Award of Contract	<p>All tenderers will be informed (via email) of the outcome of their proposals following tender evaluation and any necessary clarifications. Potential outcomes can be:</p> <ul style="list-style-type: none"> (a) Notification for award of contract. (b) Notification of Regret. <p>GNTZ will award the Contract to the Tenderer whose tender has been determined to be substantially responsive to the tendering documents, who has all the rights and legal capacity to enter into a contract for procurement.</p>
Performance of Service	<p>In contract execution supplier should consider the following,</p> <ul style="list-style-type: none"> ● Prices quoted by the Bidder shall be fixed during the Bidder's performance of the Contract and not subject to variation. ● Approved sample for school desk shall not change, unless agreed before delivery of service.

Currency and Payment	<ul style="list-style-type: none"> - The currency and invoices in which all prices and rates shall be tendered, and which payments under the contract will be paid, shall be in Tanzania Shillings. - GNTZ will make payment within 21 Working days after delivery of Items or services. During delivery, Supplier shall provide Delivery Note, Invoice and EFD receipt. The payments will be made to the respective Account of Supplier or Company. - No advance payments will be allowed in the Purchasing Process.
Termination of contract	<p>GNTZ will terminate the Agreement If,</p> <ol style="list-style-type: none"> i. Late deliveries occur during performance of contract ii. Supplier decides to change Item Brand without GNTZ consent. iii. Supplier deliver's items below standards expected by the Client. iv. Supplier doesn't adhere to the terms and conditions of the agreed service contract or mutual consents. v. Supplier doesn't adhere to ethical Standards. vi. Any other reason based on the laws and regulations of the United Republic of Tanzania.
Corrupt or fraudulent Practices	<ul style="list-style-type: none"> - GNTZ requires that bidders observe the highest standards of ethics during the selection and award of contract and also during the performance of the service or task. - GNTZ will reject a proposal for award if it determines that the bidder recommended for awards has engaged in corrupt or fraudulent practices in competing for the contract in question. - Bidders may raise any suspicion of misconduct or unfair treatment to email:gntzHO@goodneighbors.or.tz
Compliance to Safeguarding Policy	<p>All tenderers shall conform to GNTZ Safeguarding Policy as below,</p> <ul style="list-style-type: none"> ● Supplier shall comply with the Convention on the Rights of the Child which requires that a child shall be protected from economic exploitation and from performing any work that is likely to be hazardous or to interfere with the child's education, or to be harmful to the child's health or physical, mental, spiritual, moral or social development. ● Supplier shall take all appropriate measures to prevent sexual harassment and sexual exploitation and abuse of anyone by themselves or its employees, or related personnel controlled by the Supplier in execution of this work. ● Sexual activity with any person under the age of 18 is prohibited. ● Exchange of money, employment, goods or goods for sex is prohibited. Any of these practices shall be grounds for elimination to participation on this tender.

ANNEX 1 Schedule of Requirements and prices for School Desks for Primary Schools at Bahi and Chamwino District, Dodoma Region.

S/N	Item	Description	Unit	Quantity	Amount	Remarks
1.	School Desks	1100mm long *740mm high overall size, Pupils Desk made from Hardwood well finished and varnish /polished, consist of hardwood frame 50*75mm horizontal bottom rails, 25 *25mm vertical supporting frame both sides, hardwood seat size 225mm*1100mm*20mm thick frame well finished and polished placed 410mm from bottom rail, 331mm*1100mm* 20mm thick deskwork top including middle rail size 331mm*1100mm long * 20mm thick deskwork top including middle rail size 331mm*1100mm long * 20mm thick well finished metal frames painted two undercoats ant rust metal frames painted two undercoats ant rust metal primer and two coats black high glass paint ,including all necessary materials as per drawings	pcs	200		40 pcs Sasajila Primary School 60 pcs Ilewelo Primary School 50 pcs Nagulo Bahi primary School 50pcs Uhelela Primary School
NET AMOUNT						
VAT (18%)						If applicable
GRAND TOTAL						

ANNEX 2: Drawings for Furniture

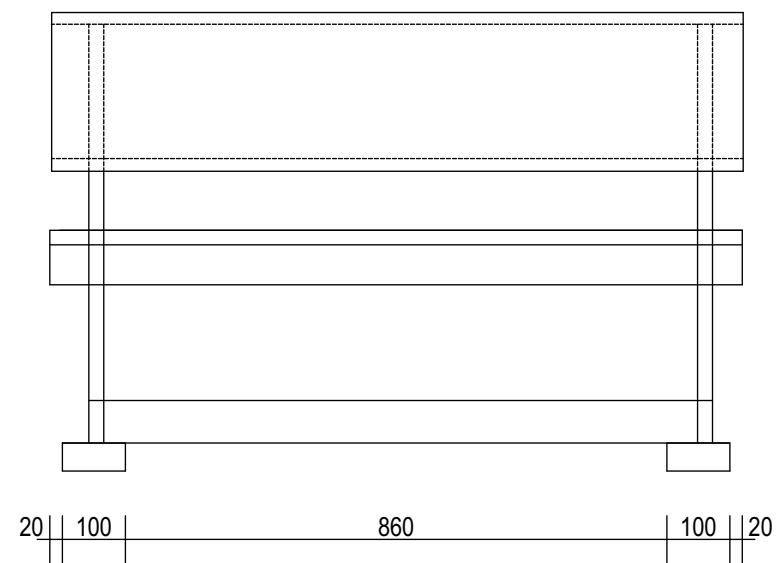

FRONT ELEVATION

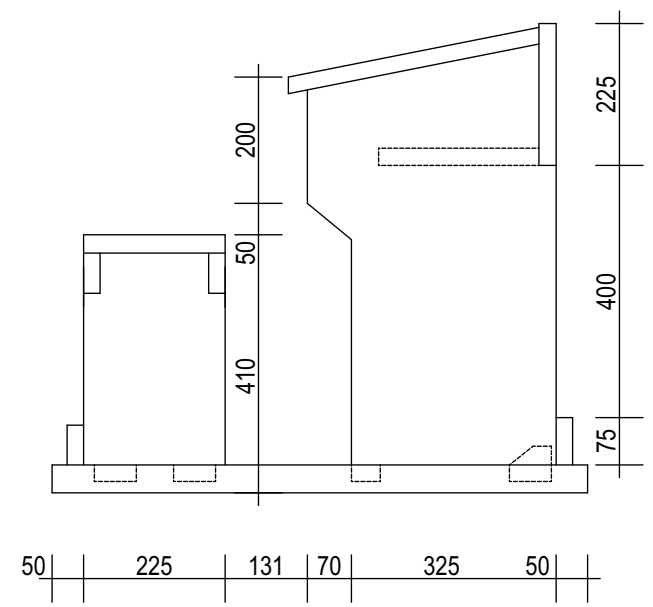

SIDE ELEVATION

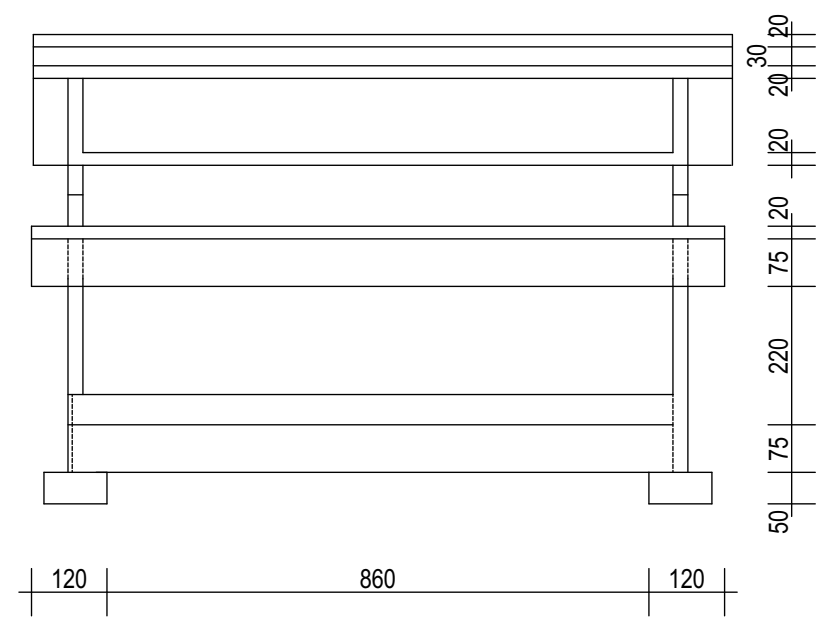

REAR ELEVATION

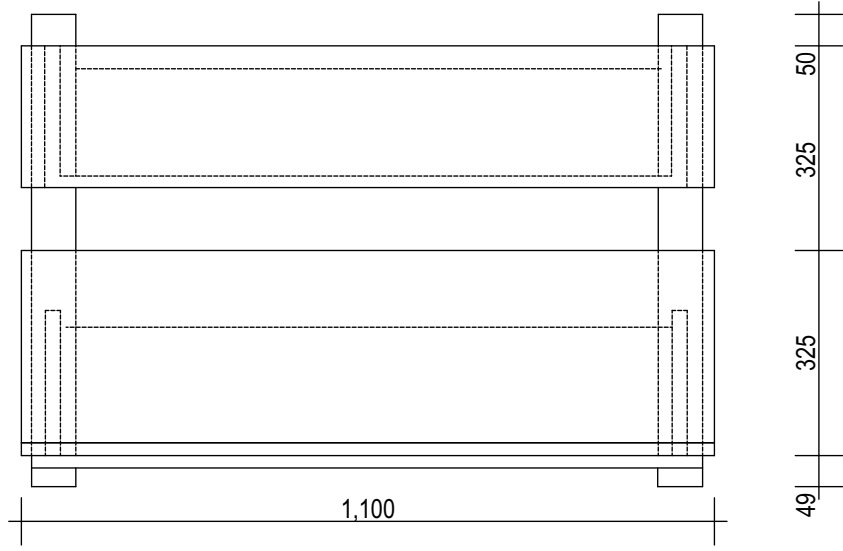

PLAN

NOTE

- USE HARDWOOD TIMBER
- ALL WOODEN SURFACE SHALL BE WELL SANDED AND FINISHED WITH THE COATS OF CLEAR VANISH
- FIXING SHALL BE TIMBER DOWELS PROPERLY GLUED AND SCREWS



FRONT ELEVATION

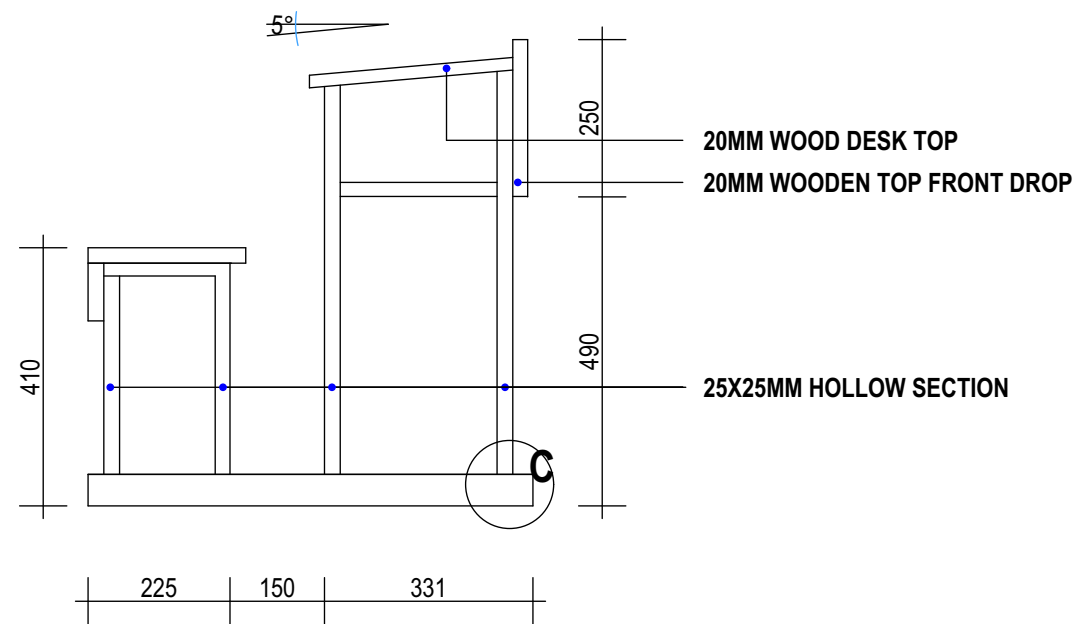

SIDE ELEVATION

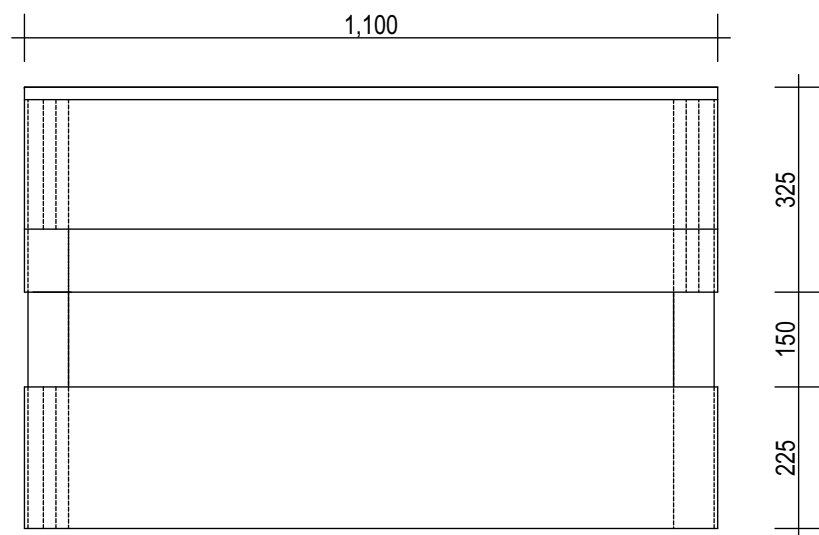

PLAN

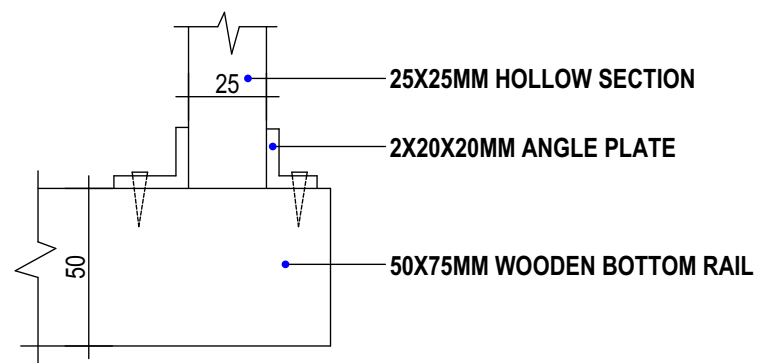

DETAIL C

NOTE

- ALL WOODEN SURFACE SHALL BE WELL SANDED AND FINISHED WITH THE COATS OF CLEAR VANISH
- ALL METAL SURFACE WILL HAVE TWO COATS OF BLACK OIL PAINT OVER TWO COATS OF RED OXIDE PRIMER