

**THE UNITED REPUBLIC OF TANZANIA
PRESIDENT'S OFFICE REGIONAL ADMINISTRATION AND LOCAL
GOVERNMENT**



BID DOCUMENT

Bid No. GNTZ/HO/011/2024

For

**RENOVATION OF CLASSROOMS AND OFFICE AT UHELELA PRIMARY
SCHOOL, SUPPORTING BUILDING MATERIALS FOR CONSTRUCTION OF
INCINERATOR, ASH PIT AND PLACENTA PIT AT MKAKATIKA
DISPENSARY, BAHI -DODOMA REGION**

SECTION I: INVITATION FOR TENDERS



Bid No. GNTZ/HO/011/2024

for

RENOVATION OF CLASSROOMS AND OFFICE AT UHELELA PRIMARY SCHOOL, SUPPORTING BUILDING MATERIALS FOR CONSTRUCTION OF INCINERATOR, ASH PIT AND PLACENTA PIT AT MKAKATIKA DISPENSARY, BAHI -DODOMA REGION

Invitation for Tenders

Date: 31st July 2024

1. The Good Neighbors Tanzania has a plan to renovate three classroom blocks at Uhelela village and supply building materials with construction of incinerator, Ash pit, placenta pit together with all finishing work (doors, plumbing and electrical) for Mkakatika Dispensary at Mkakatika village of Bahi District - Dodoma Region and it intends to implement the plan by hiring a qualified contractor according to its internal policy and secured budget for this project.

Nb: for renovation work at Uhelela village it includes; - Supply and fixing different size of windows(39no.) and doors(11no.), Floor screed(437Sqm), plastering for plinth rectification(900Sqm), Ceiling(437Sqm), internally and externally painting(85Sqm)

2. The Good Neighbors Tanzania now invites sealed tenders from eligible Tanzanian contractors registered in Class VII and above for renovation of classrooms and office at Uhelela primary school, supporting building materials for construction of incinerator, ash pit and placenta pit at Mkakatika dispensary, Bahi - Dodoma region.

3. Bidders may request a clarification of bidding document only up to Three (3) days before the Bid submission deadline by sending email to HOllogistics@goodneighbors.or.tz
4. A complete set of Bid Document(s) in English and additional sets are freely accessible through Good Neighbors Tanzania Website: <https://www.goodneighbors.or.tz/tenders-2/>
5. All Tenders must be accompanied by a Tender Securing Declaration in the format provided in the Tendering Documents.
6. All Tenders in one original plus two (2) copies, properly filled in, and enclosed in plain envelopes must be delivered to the address Good Neighbors Tanzania, Head Office Dar es Salaam, along Bagamoyo road, Boko area, near Chama before 10:00AM, **21st August 2024**. Tenders will be opened promptly thereafter in public and in the presence of Tenderers' representatives who choose to attend.
7. Late tenders, portion of tenders, electronic tenders, tenders not received, tenders not opened and not read out in public at the tender opening ceremony shall not be accepted for evaluation irrespective of the circumstance.

[Good Neighbors Tanzania -Head Office]

SECTION II: INSTRUCTIONS TO TENDERERS

Table of Clauses

Sec. II

A. Introduction	0
1. Scope of Tender	0
2. Source of Funds	0
3. Eligible Tenderers	0
4. One Tender per Tenderer	3
5. Cost of Tendering	4
6. Site Visit and Pre-Tender Meeting	4
B. Tendering Documents	5
7. Content of Tendering Documents	5
8. Clarification of Tendering Documents	6
9. Amendments of the Tendering Documents	6
C: Preparation of Tenders	7
10. Language of Tender	7
11. Documents Constituting the Tender	8
12. Documents Establishing Eligibility and Qualifications of the Tenderer	8
13. Slice and Package	10
14. Form of Tender	10
15. Tender Prices	10
16. Tender Currencies	11
17. Tender Validity Period	11
18. Tender Security or Bid Securing Declaration	12
19. Alternative Tenders by Tenderers	14
20. Format and Signing of Tender	15
D. Submission of Tenders	15
21. Sealing and Marking of Tenders	15
22. Deadline for Submission of Tenders	16
23. Late Tenders.....	17
24. Modification, Substitution and Withdrawal of Tenders	17

E. Opening and Evaluation of Tenders.....	18
25. Opening of Tenders	18
26. Confidentiality	19
27. Clarification of Tenders	20
28. Preliminary Examination of Tenders	20
29. Correction of Errors	23
30. Conversion to Single Currency	23
31. Comparison of Tenders	24
32. National Preference	25
33. Determination of the Lowest Evaluated Tender	25
34. Post-qualification of Tenderer	25
F. Award of Contract.....	27
35. Criteria of Award	27
36. Negotiations	27
37. PE's Right to Accept any Tender and to Reject any or all Tenders	28
38. Procuring Entities Right to Vary Quantities at the Time of Award	28
39. Time Limit on Review	28
40. Signing of Contract	29
41. Performance Security	29
42. Advance Payment	30
43. Adjudicator	30
44. Fraudulent, Corrupt, Coercive, Collusive or Obstructive Practices	30
G. Review of Procurement Decisions	33
45. Right to Review	33
46. Time Limit on Review	33
47. Submission of Applications for Review	33
48. Decision by the Head of PE	33
49. Review by the Public Procurement Appeals Authority (PPAA)	34

		A. Introduction
1. Scope of Tender	1.1	The Procuring Entity (PE) indicated in the Tender Data Sheet (TDS) invites Tenders for the construction of works as specified in the TDS and Section VII, Specification.
	1.2	The successful Tenderer will be expected to complete the works by the required completion date specified in the TDS .
	1.3	Unless otherwise stated, throughout this bidding document definitions and interpretations shall be as prescribed in General Conditions of Contract.
2. Source of Funds	2.1	The Good Neighbor Tanzania has set aside sufficient funds for the operations of the PE named in the TDS during the Financial Year indicated in the TDS . It is intended that part of the proceeds of the funds will be applied to cover eligible payments under the contract for the works as described in the TDS . Or The Good Neighbors Tanzania has set aside sufficient funds towards the cost of the Project named in the TDS . The United Republic of Tanzania intends to apply a part of the proceeds of this [loan/credit/grant] to payments under the Contract described in the TDS .
	2.2	Payments will be made directly by the PE (or by financing institution specified in the TDS upon request of the PE to so pay) and will be subject in all respects to the terms and conditions of the resulting contract placed by the PE.

3. Eligible Tenderers	3.1	<p>A Tenderer may be natural persons, companies or firms or public or semi-public agencies of Tanzania and foreign countries, subject to ITT 3.4 or any combination of them with a formal intent or letter of intent to enter into an agreement or under an existing agreement in the form of a joint venture, consortium, or association.</p> <p>In the case of a joint venture, consortium, or association, all members shall be jointly and severally liable for the execution of the Contract in accordance with the Contract terms. The joint venture, consortium, or association shall</p>
-----------------------	-----	--

		<p>nominate a Lead Member who shall have the authority to conduct all business for and on behalf of any and all the members of the joint venture, consortium, or association during the tendering process and, in the event the joint venture, consortium, or association is awarded the Contract, during contract execution. Unless specified in the TDS, there is no limit on the number of members in a joint venture, consortium, or association.</p>
	3.2	<p>The appointment of a Lead Member in the joint venture, consortium, or association shall be confirmed by submission of a valid Power of Attorney to the PE.</p>
	3.3	<p>Any agreement that form a joint venture, consortium or association shall be required to be submitted as part of the tender and shall be attested.</p>
	3.4	<p>Any Tender from a joint venture, consortium or association shall indicate the part of proposed contract to be performed by each party and each party shall be evaluated or post qualified with respect to its contribution only and the responsibilities of each party and shall not be substantially altered without prior written approval of the PE.</p>
	3.5	<p>The invitation for Tenders is open to all Tenderers as defined in the Public Procurement Regulations, 2013 – Government Notice No. 446, and Public Procurement (Amendment) Regulations, 2016 – Government Notice No. 333 except as provided hereinafter.</p>

	3.6	National Tenderers shall satisfy all relevant licensing and/or registration with the appropriate statutory bodies in Tanzania.
	3.7	<p>A Tenderer shall not have a conflict of interest. All Tenderers found to have a conflict of interest shall be disqualified. A Tenderer may be considered to have a conflict of interest with one or more parties in this tendering process, if they:</p> <p>a) Are associated or have been associated in the past, directly or indirectly with a firm or any of its affiliates which have been engaged by the PE to provide consulting services for the preparation of the design, specifications and other documents to be</p>
		<p>used for the procurement of the works under this Invitation for Tenders.</p> <p>b) have controlling shareholders in common; or</p> <p>c) receive or have received any direct or indirect subsidy from any of them; or</p> <p>d) have the same legal representative for purposes of this Tender; or</p> <p>e) have a relationship with each other, directly or through common third parties, that puts them in a position to have access to information about or influence on the Tender of another Tenderer, or influence the decisions of the PE regarding this tendering process; or</p> <p>f) submit more than one Tender in this tendering process, However, this does not limit the participation of subcontractors in more than one Tender, or as Tenderers and subcontractors simultaneously; or</p> <p>g) Participated as a consultant in the preparation of the design or technical specifications of the works and related services that are the subject of the Tender.</p>

	3.8	<p>A Tenderer may be ineligible if –</p> <ul style="list-style-type: none"> (a) the Tenderer is declared bankrupt or, in the case of company or firm, insolvent; (b) payments in favor of the Tenderer is suspended in accordance with the judgment of a court of law other than a judgment declaring bankruptcy and resulting, in accordance with the national laws, in the total or partial loss of the right to administer and dispose of its property; (c) legal proceedings are instituted against such tenderer involving an order suspending payments and which may result, in accordance with the national laws, in a declaration of bankruptcy or in any other situation entailing the total or partial loss of the right to administer and dispose of the property;
--	-----	--

		<ul style="list-style-type: none"> (d) the tenderer is convicted, by a final judgment, of any offence involving professional conduct; (e) the Tenderer is debarred and blacklisted in accordance with Section 62 of the Act or ineligible in accordance with Section 84(7) of the Act as amended in 2016, from participating in public procurement for corrupt, coercive, collusive, fraudulent or obstructive practices, failure to abide with a Bid Securing Declaration, breach of a procurement contract, making false representation about his qualifications during tender proceeding or other grounds as may be deemed necessary by the Authority company or firm is found guilty of serious misrepresentation with regard to information required for participation in an invitation to tender or to submit proposals.
--	--	--

	3.9	Public or Semi-public owned enterprises in the United Republic of Tanzania may participate only if they are legally and financially autonomous, if they operate under commercial law, are registered by the relevant registration board or authorities and if they are not a dependent agency of the Government.
	3.10	Tenderers shall provide to the PE evidence of their eligibility, proof of compliance with the necessary legal, technical and financial requirements and their capability and, adequacy of resources to carry out the contract effectively.
	3.11	Tenderers shall provide such evidence of their continued eligibility satisfactory to the PE, as the PE shall reasonably request.
	3.12	Tenderers shall, if so indicated in the TDS , submit proposals relating to the nature, conditions and modalities of sub-contracting wherever the sub-contracting of any elements of the contract amounting to more than ten percent of the tender price is envisaged.
4. One Tender per Tenderer	4.1	A firm shall submit only one Tender, in the same tendering process, either individually as a Tenderer or as a partner in a joint venture.
	4.2	No firm can be a subcontractor while submitting a Tender

		individually or as a partner of a joint venture in the same tendering process.
	4.3	A firm, if acting in the capacity of subcontractor in any Tender, may participate in more than one Tender but only in that capacity.
	4.4	A Tenderer who submits or participates in more than one Tender (other than as a subcontractor or in cases of alternatives that have been permitted or requested) will cause all the Tenders in which the Tenderer has participated to be disqualified.

5. Cost of Tendering	5.1	The Tenderer shall bear all costs associated with the preparation and submission of his Tender, and the PE will in no case be responsible or liable for those costs except in the circumstances described in Section 97(5) (f) of the Public Procurement Act No. 7 of 2011 as amended in 2016.
6. Site Visit and Pretender Meeting	6.1	The Tenderer, at the Tenderer's own responsibility and risk, is advised to visit and examine the Site of Works and its surroundings and obtain all information that may be necessary for preparing the Tender and entering into a contract for construction of the Works. The costs of visiting the Site shall be at the Tenderer's own expense.
	6.2	The PE may conduct a site visit and a pre-tender meeting. The purpose of the pre-tender meeting will be to clarify issues and to answer questions on any matter that may be raised at that stage. However, THIS OPTION IS NOT MANDATORY.
	6.3	The Tenderer's designated representative is invited to attend a site visit and pre-tender meeting which, if convened, will take place at the venue and time stipulated in the TDS.
	6.4	The Tenderer is requested as far as possible, to submit any questions in writing or electronic forms that provide record of the content of communication to reach the PE before the pre-tender meeting. It may not be practicable at the meeting to answer all questions, but questions and responses will be transmitted in accordance with ITT 6.5.
	6.5	Minutes of the pre-tender meeting, including the text of the questions raised and the responses given together with
		any responses prepared after the pre-tender meeting will be transmitted within three (3) days to all purchasers of the Tendering Documents. Any modification of the Tendering Documents listed in ITT 7.1 [Content of Tendering Documents] that may become necessary as a result of the pre-tender meeting shall be made by the PE exclusively through the issue of an Addendum pursuant to ITT 9.2 [Amendments of the Tendering Documents] and not through the minutes of the pre-tender meeting.

		B. Tendering Documents
7. Content of Tendering Documents	7.1	The works required, tendering procedures, and contract terms are prescribed in the Tendering Documents. In addition to the Section I Invitation for Tenders, Tendering Documents which should be read in conjunction with any addenda issued in accordance with ITT 9.2 [Amendments of the Tendering Documents] include:
		Section II Instructions to Tenderers; Section III Tender Data Sheet; Section IV General Conditions of Contract; Section V Special Conditions of Contract; Section VI Specifications; Section VII Drawings; Section VIII Bill of Quantities; Section IX Tender Forms; <ul style="list-style-type: none"> • Form of Tender and Appendix to Tender; • Forms of Qualification Information; • Letter of Acceptance; • Form of Contract Agreement Section X Tender Security; <ul style="list-style-type: none"> • Bid Securing Declaration or • Tender Security Form • Performance Security Form • Bank Guarantee for Advance Payment Form Section XI Forms of Integrity
	7.2	The number of copies to be completed and returned with the Tender is specified in the TDS .
	7.3	The Invitation for Tenders (Section I) issued by the PE is not part of the Tendering Documents. In case of discrepancies between the Invitation for Tender and the

		Tendering Documents listed in ITT 7.1, said Tendering Documents will take precedence.
	7.4	The PE is not responsible for the completeness of the Tendering Documents and their addenda, if they were not obtained directly from the PE.
	7.5	The Tenderer is expected to examine all instructions, forms, terms and specifications in the Tendering Documents. Failure to furnish all information required by the Tendering Documents or to submit a Tender substantially responsive to the Tendering Documents in every respect will be at the Tenderer's risk and may result in the rejection of its Tender.
8. Clarification of Tendering Documents	8.1	A prospective Tenderer requiring any clarification of the Tendering Documents may notify the PE in writing or electronic forms that provide record of the content of communication at the PE's address indicated in the TDS .
	8.2	The PE will within three (3) working days after receiving the request for clarification respond in writing or electronic forms that provide record of the content of communication to any request for clarification provided that such request is received no later than the fourteen (14) days prior to the deadline for the submission of competitive Tenders prescribed in ITT 22.1 [Deadline for Submission of Tenders] and in the case of non-competitive methods, three (3) days prior to the deadline.
	8.3	Copies of the PE's response will be forwarded to all Purchasers of the Tendering Documents, including a description of the inquiry, but without identifying its source.
	8.4	Should the PE deem it necessary to amend the Tendering Documents as a result of a clarification, it shall do so following the procedure under ITT 9 [Amendments of the Tendering Documents].
9. Amendments of the Tendering Documents	9.1	Before the deadline for submission of tenders, the PE for any reason, whether at its own initiative or in response to a clarification requested by a prospective Tenderer, the PE may modify the Tendering Documents by issuing addenda.

	9.2	Any addendum issued including the notice of any extension of the deadline shall be part of the Tendering
		Document pursuant to ITT 7.1 [Content of Tendering Documents] and shall be communicated in writing or electronic forms that provide record of the content of communication to Tenderers to which the PE provided the Tendering Documents.
	9.3	In order to allow prospective Tenderers reasonable time in which to take an addendum into account in preparing their Tenders, the PE at its discretion shall extend, as necessary, the deadline for submission of Tenders, in accordance with sub-ITT 22.2 [Deadline for Submission of Tenders].
		C: Preparation of Tenders
10. Language of Tender	10.1	The Tender, and all correspondence and documents related to the Tender exchanged by the Tenderer and the PE, shall be written in the Tender language stipulated in the TDS. Supporting documents and printed literature furnished by the Tenderer may be in another language provided they are accompanied by an accurate translation of the relevant passages in the above stated language, in which case, for purposes of interpretation of the Tender, the translation shall prevail.

<p>11. Documents Constituting the Tender</p>	<p>11.1</p>	<p>The Tender submitted by the Tenderer shall comprise the following:</p> <ul style="list-style-type: none"> a) The Form of Tender (in the format indicated in Section IX) in accordance with ITT 14 [Form of Tender], 15 [Tender Currencies] and 16 [Tender Currencies]; b) Information requested by Instructions to Tenderers ITTs 12.2; 12.3 and 12.4 [Documents Establishing Eligibility and Qualifications of the Tenderer]; c) Tender security or Tender securing declaration in accordance with Instructions to Tenderers ITT 18 [Tender Security or Bid Securing Declaration]; d) Priced Bill of Quantities; e) Qualification Information Form and Documents; f) Alternative offers where invited in accordance with Instructions to Tenderers ITT 19 [Alternative Tenders by Tenderers]; g) Dully Notarized power of attorney authorizing signatory of the Tender to commit the Tenderer in accordance with ITT sub Clause 20.2 [Format and Signing of Tender]; and h) any information or other materials required to be completed and submitted by Tenderers, as specified in the TDS.
<p>12. Documents Establishing Eligibility and Qualifications of the Tenderer</p>	<p>12.1</p>	<p>Pursuant to ITT 12, the Tenderer shall furnish, as part of its Tender, documents establishing the Tenderer's eligibility to Tender and its qualifications to perform the contract if its Tender is accepted.</p>

	12.2	<p>In the event that pre-qualification of potential Tenderers has been undertaken, only Tenders from pre-qualified Tenderers will be considered for award of contract. These qualified Tenderers should submit their Tenders with any information updating the original pre-qualification applications or, alternatively, confirm in their Tenders that the originally submitted pre-qualification information remains essentially correct as of the date of Tender submission. The update or confirmation should be provided in Section IX.</p>
	12.3	<p>If the PE has not undertaken pre-qualification of potential Tenderers, to qualify for award of the contract, Tenderers shall meet the minimum qualifying criteria specified in the Section IX - Tender Forms: Form of Qualification Information.</p>
	12.4	<p>Tenders submitted by a joint venture, consortium or association shall comply with the following requirements, unless otherwise stated in the TDS:</p> <ul style="list-style-type: none"> a) the Tender shall include all the information listed in the TDS pursuant to ITT 12.3 above for each joint venture partner; b) the Tender shall be signed so as to be legally binding on all partners; c) one of the partners will be nominated as being in charge, and this authorization shall be evidenced by submitting a Power of Attorney signed by legally authorized signatories of all the partners; d) the partner in charge shall be authorized to incur liabilities and receive instructions for and on behalf of any and all partners of a joint venture and the entire execution of the Contract, including payment, shall be done exclusively with the partner in charge; e) all partners of the joint venture shall be liable jointly and severally for the execution of the contract in accordance with the contract terms and a statement to this effect shall be included in the authorization mentioned under (c) above as well as in the Tender

		and in the Agreement (in case of a successful Tender); and
		<p>f) a copy of the joint venture agreement into by all partners shall be submitted with the Tender. Alternatively, a Letter of Intent to execute a joint venture agreement in the event of a successful Tender shall be signed by all partners and submitted with the Tender, together with a copy of the proposed Agreement;</p> <p>g) the Tender Security or Bid Securing Declaration as stated in accordance with ITT 18 [Tender Security or Bid Securing Declaration], and in case of a successful Tender, the Agreement, shall be signed so as to be legally binding on all partners.</p>
13. Slice and Package	13.1	<p>When tendering for more than one contract under the slice and package arrangements, the Tenderer must provide evidence that it meets or exceeds the sum of all the individual requirements for the slices or lots being tendered in regard to: -</p> <ul style="list-style-type: none"> a) average annual turnover; b) particular experience including key production rates; c) financial means; d) personnel capabilities; and e) Equipment capabilities.
	13.2	In case the Tenderer fails to fully meet any of these criteria, it may be qualified only for those slices for which the Tenderer meets the above requirement.
14. Form of Tender	14.1	The Tenderer shall fill the Form of Tender furnished in the Tendering Documents. The Form of Tender must be completed without any alterations to its format and no substitute shall be accepted.
15. Tender Prices	15.1	The Contract price shall be for the whole Works, as described in ITT 1.1 [Scope of Tender], based on the priced Bill of Quantities submitted by the Tenderer.

	15.2	The Tenderer shall fill in rates and prices for all items of the Works described in the Bill of Quantities. Items for which no rate or price is entered by the Tenderer will not be paid for by the PE when executed and shall be deemed covered by the other rates and prices in the Bill of quantities.
	15.3	All duties, taxes and other levies payable by the Contractor under the Contract as provided in the TDS , or for any other cause, as of the date 28 days prior to the deadline for submission of Tenders, shall be included in the rates, prices and total Tender price submitted by the Tenderer.
	15.4	The rates and prices quoted by the Tenderer shall be subject to adjustment during the performance of the Contract if provided for in the TDS and the provisions of the Conditions of Contract. The Tenderer shall submit with the Tender all the information required under the SCC .
16. Tender Currencies	16.1	The unit rates and prices shall be quoted by the Tenderer entirely in Tanzania shillings or as specified in the TDS .
	16.2	In case of a foreign tenderer, the rates of exchange to be used by the Tenderer in arriving at the local currency equivalent shall be the selling rates for similar transactions established by the authority specified in the TDS prevailing on the date 28 days prior to the latest deadline for submission of Tenders.
	16.3	Tenderers may be required by the PE to clarify their foreign currency requirements and to substantiate that the amounts included in the rates and prices and in the SCC are reasonable and responsive to ITT 16.1.
17. Tender Validity Period	17.1	Tenders shall remain valid for the period specified in the TDS after the Tender submission deadline prescribed by the PE, pursuant to ITT 22 [Deadline for Submission of Tenders]. A Tender valid for a shorter period shall be rejected by the PE as non-responsive.

	17.2	In exceptional circumstances, prior to expiry of the original Tender validity period, the PE may request that the Tenderers to extend the period of validity for a specified additional period. The request and the Tenderers' responses shall be made in writing or by electronic forms that provide record of the content of communication. A Tenderer may refuse the request without forfeiting its Tender security or causing to be executed its Tender securing declaration. A Tenderer agreeing to the request will not be required or permitted to otherwise modify the Tender, but will be required to extend the validity of its Tender security or Tender Securing declaration for the
		period of the extension, and in compliance with ITT 18 [Tender Security or Bid Securing Declaration] in all respects.
	17.3	In the case of fixed price contracts, if the award is delayed by a period exceeding sixty (60) days beyond the expiry of the initial Tender validity period, the contract price may be adjusted by a factor specified in the request for extension. The Tender evaluation shall be based on the Tender price without taking into consideration on the above correction.
18. Tender Security or Bid Securing Declaration	18.1	Pursuant to ITT 11 [Documents Constituting the Tender], unless otherwise specified in the TDS , the Tenderer shall furnish as part of its Tender, a Tender Security in original form and in the amount and currency specified in the TDS or Bid Securing Declaration as specified in the TDS in the format provided in Section IV.
	18.2	The Tender Security or Bid Securing Declaration is required to protect the PE against the risk of Tenderer's conduct which would warrant the security's forfeiture, pursuant to ITT 18.9 [Tender Security].

	18.3	<p>The Tender Security shall be denominated in the currency of the Tender or in another freely convertible currency, and it shall be in the form specified in the TDS which shall be in any of the following:</p> <ul style="list-style-type: none"> a) a bank guarantee, an irrevocable letter of credit issued by a reputable bank, or an insurance bond issued by a reputable insurance firm of their choice located in any eligible country, in the form provided in the Tendering Documents or another form acceptable to the PE and valid for twenty eight (28) days beyond the end of the validity of the Tender. This shall also apply if the period for Tender validity is extended. In either case, the form must include the complete name of the Tenderer; or, b) a cashier's or certified cheque. c) another security if indicated in the TDS (i) sign the contract, or (ii) furnish the required performance security
	18.4	<p>The Tender Security or Bid Securing Declaration shall be in accordance with the Forms included in Section VIII or another form approved by the PE prior to the Tender submission.</p>
	18.5	<p>The Tender Security shall be payable promptly upon written demand by the PE in case any of the conditions listed in ITT 18.9 are invoked.</p>
	18.6	<p>Any Tender not accompanied by a Tender security in accordance with ITTs 18.1 or 18.3 shall be rejected by the PE as non-responsive, pursuant to ITT 28 [Preliminary Examination of Tenders].</p>

	18.7	<p>Unsuccessful Tenderers' Tender security will be discharged or returned as promptly as possible not later than thirty (30) days after the expiration of the period of Tender validity prescribed by the PE pursuant to ITT 17 [Tender Validity Period]. The PE shall make no claim to the amount of the tender security, and shall promptly return the tender security document, after whichever of the following that occurs earliest:</p> <ul style="list-style-type: none"> (a) the expiry of the tender security; (b) the entry into force of a procurement contract and the provision of a security for the performance of the contract if such a security is required by the solicitation documents; (c) the rejection by the PE of all tenders; (d) the withdrawal of the tender prior to the deadline for the submission of tenders, unless the solicitation documents stipulate that no such withdrawal is permitted.
	18.8	<p>The successful Tenderer's Tender security will be discharged upon the Tenderer signing the contract, pursuant to ITT 40 [Signing of Contract], and furnishing the performance security, pursuant to ITT 41 [Performance Security].</p>
	18.9	<p>The Tender security may be forfeited or the Tender securing declaration executed:</p> <ul style="list-style-type: none"> a) if a Tenderer <ul style="list-style-type: none"> i) withdraws its Tender during the period of Tender validity specified by the Tenderer on the Tender

		<p>Form except as provided for in ITT 17.2 [Tender Validity Period]; or</p> <p>ii) does not accept the correction of errors pursuant to ITT 29 [Correction of Errors]; or</p> <p>b) in the case of a successful Tenderer, if the Tenderer fails:</p> <p>i) to sign the contract in accordance with ITT 40 [Signing of Contract]; or</p> <p>ii) to furnish performance security in accordance with ITT 41 [Performance Security].</p>
	18.10	The Tender Security or Bid Securing Declaration of a joint venture must be in the name of the joint venture submitting the Tender.
	18.11	<p>A Tenderer shall be suspended from being eligible for tendering in any contract with the PE for the period of time indicated in the Tender Securing Declaration:</p> <p>(a) if the Tenderer withdraws its Tender, except as provided in ITTs 17.2 [Tender Validity] Period and Clause 29 [Correction of Errors]; or</p> <p>(b) in the case of a successful Tenderer, if the Tenderer fails within the specified time limit to:</p> <p>(i) sign the contract, or</p> <p>(ii) furnish the required performance security</p>
19. Alternative Tenders by Tenderers	19.1	Tenderers shall submit offers that comply with the requirements of the Tendering Documents, including the basic Tenderer's technical design as indicated in the specifications and Drawings and Bill of Quantities. Alternatives will not be considered, unless specifically allowed for in the TDS . If so allowed, ITT 19.2 and 19.3 shall govern.
	19.2	When alternative times for completion are explicitly invited, a statement to that effect will be included in the TDS as will the method of evaluating different times for completion.

	19.3	If so allowed in the TDS , Tenderers wishing to offer
		technical alternatives to the requirements of the Tendering Documents must also submit a Tender that complies with the requirements of the Tendering Documents, including the basic technical design as indicated in the specifications. In addition to submitting the basic Tender, the Tenderer shall provide all information necessary for a complete evaluation of the alternative by the PE, including technical specifications, breakdown of prices, and other relevant details. Only the technical alternatives, if any, of the lowest evaluated Tenderer conforming to the basic technical requirements shall be considered by the PE.
20. Format and Signing of Tender	20.1	The Tenderer shall prepare one original of the documents comprising the Tender as described in ITT 11 [Documents Constituting the Tender] of these Instructions to Tenderers, with the Form of Tender, and clearly marked "ORIGINAL". In addition, the Tenderer shall submit copies of the Tender, in the number specified in the TDS , and clearly marked as "COPIES". In the event of discrepancy between them, the original shall prevail.
	20.2	The original and all copies of the Tenders shall be typed or written in indelible ink and shall be signed by a person or persons duly authorized to sign on behalf of the Tenderer. This authorization shall consist of a written confirmation as specified in the TDS and shall be attached to the Tender. The name and position held by each person signing the authorization must be typed or printed below the signature. All pages of the Tender, except for unamended printed literature, shall be initialed by the person or persons signing the Tender.
	20.3	Any interlineations, erasures, or overwriting shall be valid only if they are initialed by the person or persons signing the Tender.
		The Tenderer shall furnish information as described in the Form of Tender on commissions or gratuities, if any, paid or to be paid to agents relating to this Tender and to contract execution if the Tenderer is awarded the contract
		D. Submission of Tenders

21. Sealing and marking of Tenders	21.1	The Tenderer shall seal the original and each copy of the Tender in separate envelopes, duly marking the envelopes as "ORIGINAL" and "COPY." The envelopes
		shall then be sealed in an outer envelope securely sealed in such a manner that opening and resealing cannot be achieved undetected.
	21.2	The inner and outer envelopes shall: a) be addressed to the PE at the address given in the TDS ; and b) bear the Project name indicated in the TDS , the Invitation for Tenders (IFT) title and number indicated in the TDS , and a statement: "DO NOT OPEN BEFORE," to be completed with the time and the date specified in the TDS , pursuant to ITT 22.1 [Deadline for Submission of Tenders].
	21.3	In addition to the identification required in ITT 21.2, the inner envelopes shall also indicate the name and address of the Tenderer to enable the Tender be returned unopened in case it is declared late, pursuant to ITT 22.1 [Deadline for Submission of Tenders] and for matching purpose under ITT 24 [Modification, Substitution and Withdrawal of Tenders].
	21.4	If all envelopes are not sealed and marked as required by ITT 21.1, 21.2 and 21.3, or incorrectly marked the PE shall assume no responsibility for the misplacement or premature opening of the Tender.
	21.5	If the outer envelope discloses the Tenderer's identity, the PE will not guarantee the anonymity of the Tender submission, but this shall not constitute grounds for rejection of the Tender.
22. Deadline for Submission of Tenders	22.1	Tenders shall be received by the PE at the address specified under ITT 21.2 [Sealing and Marking of Tenders] no later than the date and time specified in the TDS .

	22.2	The PE may, in exceptional circumstances and at its discretion, extend the deadline for the submission of Tenders by amending the Tendering Documents in accordance with ITT 9 [Amendments of the Tendering Documents], in which case all rights and obligations of the PE and Tenderers previously subject to the deadline will thereafter be subject to the new deadline.
--	------	---

	22.3	The extension of the deadline for submission of Tenders shall not be made later than the period specified in the TDS before the expiry of the original deadline.
23. Late Tenders	23.1	The PE shall not consider for evaluation any Tender that arrives after the deadline for submission of Tenders, in accordance with ITT 22 [Deadline for Submission of Tenders].
	23.2	Any Tender received by the PE after the deadline prescribed in ITT 22 [Deadline for Submission of Tenders] will be declared late, recorded, rejected and returned unopened to the Tenderer.
24. Modification, Substitution and Withdrawal of Tenders	24.1	A Tenderer may modify or substitute or withdraw its Tender after it has been submitted, provided that written notice of the modification, including substitution or withdrawal of the Tender, is received by the PE prior to the deadline prescribed for submission of Tenders prescribed under ITT 22.1 [Deadline for Submission of Tenders].
	24.2	The Tenderer's modification or substitution or withdrawal notice shall be prepared, sealed, marked, and dispatched in accordance with the provisions of ITTs 20 [Format and Signing of Tender] and 21 [Sealing and Marking of Tenders] with the outer and inner envelopes additionally marked " MODIFICATION " or SUBSTITUTION or " WITHDRAWAL " as appropriate. The notice may also be sent by electronic mail, facsimile, but followed by a signed confirmation copy, postmarked no later than the deadline for submission of Tenders.

	24.3	No Tender may be withdrawn, replaced or modified in the interval between the deadline for submission of Tenders and the expiration of the period of Tender validity specified by the Tenderer on the Tender Form. Withdrawal of a Tender during this interval shall result in the Tenderer's forfeiture of its Tender security or execution of Tender Securing Declaration, pursuant to the ITT 18.9 [Tender Security or Bid Securing Declaration].
	24.4	Withdrawal of a Tender between the deadline for submission of Tenders and the expiration of the period of Tender validity or as extended pursuant to ITT 17.2 [Tender Validity Period] shall result in the forfeiture of the Tender security or execution of Tender securing

		declaration pursuant to ITT 18.9 [Tender Security or Bid Securing Declaration].
	24.5	Tenderers may only offer discounts to, or otherwise modify the prices of their Tenders by submitting Tender modifications in accordance with this Clause, or included in the original Tender submission.
		E. Opening and Evaluation of Tenders
25. Opening of Tenders	25.1	The PE will open all Tenders including modifications, substitution or withdraw notices made pursuant to ITT 24 [Modification, Substitution and Withdrawal of Tenders], in public, in the presence of Tenderers' or representatives who choose to attend and other parties with legitimate interest and Tender proceedings, at the place on the date and at time specified in the TDS. The Tenderers' representatives who are present shall sign a register as proof of their attendance.

	25.2	Envelopes marked "WITHDRAWAL" shall be opened and read out first. Tenders for which an acceptable notice of withdrawal has been submitted pursuant to ITT 24 [Modification, Substitution and Withdrawal of Tenders] shall not be opened but returned to the Tenderer. If the withdrawal envelope does not contain a copy of the "Power of Attorney" confirming the signature as a person duly authorized to sign on behalf of the Tenderer, the corresponding Tender will be opened. Subsequently, all envelopes marked "MODIFICATION" shall be opened and the submissions therein read out in appropriate detail. Thereafter all envelopes marked or "SUBSTITUTION" opened and the submissions therein read out in appropriate detail.
	25.3	All other envelopes shall be opened one at a time. The Tenderers' names, the Tender prices, the total amount of each Tender and of any alternative Tender (if alternatives have been requested or permitted), any discounts, the presence or absence of Tender security, and such other details as the appropriate PE may consider appropriate, will be announced by the Secretary of the Tender Board or his delegate at the opening.
	25.4	Tenders or modifications that are not opened and not read out at Tender opening shall not be considered further for evaluation, irrespective of the circumstances. In particular, any discount offered by a Tenderer which is not read out
		at the Tender opening shall not be considered further.
	25.5	Tenderers are advised to send in a representative with the knowledge of the content of the Tender who shall verify the information read out from the submitted documents. Failure to send a representative or to point out any unread information by the sent Tenderer's representative shall indemnify the PE against any claim or failure to read out the correct information contained in the Tenderers Tender.
	25.6	No Tender will be rejected at Tender opening except for late Tenders which will be returned unopened to the Tenderer, pursuant to ITT 23 [Late Tenders].

	25.7	The Secretary of the appropriate Tender Board shall prepare minutes of the Tender opening. The record of the Tender opening shall include, as a minimum: the name of the Tenderer and whether or not there is a withdrawal, substitution or modification, the Tender price per Lot if applicable, including any discounts and alternative offers and the presence or absence of a Tender security or Tender Securing Declaration.
	25.8	The Tenderers' representatives who are present shall be requested to sign the record. The omission of a Tenderer's signature on the record shall not invalidate the contents and affect the record. A copy of the record shall be distributed to all the Tenderers.
	25.9	The PE shall prepare minutes of the Tender opening, including the information disclosed to those present in accordance with ITT 24.3. A copy of the minutes of the Tender opening shall be furnished to individual Tenderers upon request.
26. Confidentiality	26.1	Information relating to the examination, clarification, evaluation, and comparison of Tenders and recommendations for the award of a Contract shall not be disclosed to Tenderers or any other persons not officially concerned with such process until the award to the successful Tenderer has been announced.
	26.2	Any effort by a Tenderer to influence the PE's processing of Tenders or award decisions may result in the rejection of his Tender.
	26.3	Notwithstanding ITT 26.2, from the time of Tender opening to the time of Contract award, if any Tenderer wishes to contact the PE on any matter related to the Tendering process, it should do so in writing or electronic forms that provides record of the content of communication.

27. Clarification of Tenders	27.1	To assist in the examination, evaluation, comparison of Tenders and post-qualification of the Tenderers, the PE may, at its discretion, ask the Tenderer for a clarification of its Tender including breakdown of prices. Any clarification submitted by a Tenderer that is not in response to a request by the PE shall not be considered.
	27.2	The request for clarification and the response shall be in writing or electronic forms that provide record of the content of communication. No change in the prices or substance of the Tender shall be sought, offered, or permitted except to confirm the correction of arithmetic errors discovered by the PE in the evaluation of Tenders in accordance with ITT 29 [Correction of Errors].
	27.3	From the time of Tender opening to the time of Contract award if any Tenderer wishes to contact the PE on any matter related to the Tender it should do so in writing or electronic forms that provide record of the content of communication.
28. Preliminary Examination of Tenders	28.1	<p>Prior to the detailed evaluation of tenders, the PE will determine whether each Tender;</p> <ul style="list-style-type: none"> (a) meets the eligibility criteria defined in ITT 3 [Eligible Tenderer]; (b) has been properly signed; (c) is accompanied by the required securities; and (d) is substantially responsive to the requirements of the Tendering Documents. <p>The PE's determination of a Tender's responsiveness will be based on the contents of the Tender itself.</p>
	28.2	<p>A substantially responsive Tender is one which conforms to all the terms, conditions, and specifications of the Tendering Documents, without material deviation or reservation. A material deviation or reservation is one that:-</p> <ul style="list-style-type: none"> a) affects in any substantial way the scope, quality, or

		<p>execution of the works;</p> <p>b) limits in any substantial way, inconsistent with the Tendering Documents, the PE's rights or the Tenderer's obligations under the Contract; or</p> <p>c) if rectified, would affect unfairly the competitive position of other Tenderers presenting substantially responsive Tenders.</p>
	28.3	The PE will confirm that the documents and information specified under ITT 11 [Documents Constituting the Tender] and ITT 12 [Documents Establishing Eligibility and Qualifications of the Tenderer] have been provided in the Tender. If any of these documents or information is missing, or is not provided in accordance with the Instructions to Tenderers, the Tender shall be rejected.
	28.4	The PE may waive any minor informality, nonconformity, or irregularity in a Tender which does not constitute a material deviation, provided such waiver does not prejudice or affect the relative ranking of any Tenderer.
	28.5	If a Tender is not substantially responsive, it will be rejected by the PE, and may not subsequently be made responsive by correction or withdrawal of the nonconforming deviation or reservation pursuant to Regulation 204 (2) and 205 of GN 446 of 2013.

	28.6	<p>The PE shall confirm that the following documents and information have been provided in the Tender. If any of these documents or information is missing, or is not in accordance with the Instructions to Tenderers, the Tender shall be rejected:</p> <ul style="list-style-type: none"> a) Form of Tender; b) Information requested under ITT 12.3; c) Information requested under ITT 12.4 if Tender is submitted by joint venture; d) Information requested under ITT 12.5; e) The period of Tender validity; f) The Tender price; g) Written confirmation of authorization to commit the Tender; h) Tender security or Tender Securing Declaration; and i) Any other information/ data required by this
--	------	--

		Tendering document as specified in the TDS .
--	--	---

	28.7	<p>Material deviations to commercial terms and conditions, which justify rejection of a tender shall include the following:</p> <ul style="list-style-type: none"> a) failure to sign the bid form and price schedules by the authorized person or persons; b) failure to satisfy eligibility requirements; c) failure to submit a tender security as specified in the tendering documents; d) failure to satisfy the tender validity period; e) inability to meet the critical delivery schedule or work schedule clearly specified in the tendering documents, where such schedule is a crucial condition with which tenderers must comply; f) failure to comply with minimum experience criteria as specified in the tendering documents; g) conditional tenders such as conditions in a tender which limit the tenderer's responsibility to accept an award; h) inability to accept the price adjustment formulae of the tendering documents; i) stipulating price adjustment when fixed price tenders were invited; j) subcontracting in a substantially different amount or manner than that permitted; k) failure to submit major supporting documents required by the tendering documents to determine substantial responsiveness of a tender.
	28.8	<p>All tenders shall be checked for substantial responsiveness to the technical requirements of the tendering documents and non-conformity to technical requirements, which are justifiable grounds for rejection of a tender includes the following:</p> <ul style="list-style-type: none"> a) failure to tender for the required scope of work as instructed in the tendering documents and where failure to do so has been indicated as unacceptable; b) failure to quote for a major item in the package; c) failure to meet major technical requirements, such as offering completely different types of

		<p>equipment or materials from the types specified, plant capacity well below the minimum specified, equipment not able to perform the basic functions for which it is intended;</p> <p>d) Presentation of absolutely unrealistic and inadequate implementation plans and schedules regarding performance, technical or service factors.</p>
29. Correction of Errors	29.1	<p>Tenders determined to be substantially responsive will be checked for any arithmetic errors. Errors will be corrected as follows: -</p> <p>a) if there is a discrepancy between unit prices and the total price that is obtained by multiplying the unit price and quantity, the unit price shall prevail, and the total price shall be corrected, unless in the opinion of the PE there is an obvious misplacement of the decimal point in the unit price, in which the total price as quoted shall govern and the unit price shall be corrected;</p> <p>b) if there is an error in a total corresponding to the addition or subtraction of subtotals, the subtotals shall prevail and the total shall be corrected; and</p> <p>c) where there is a discrepancy between the amounts in figures and in words, the amount in words will govern.</p>
	29.2	<p>The amount stated in the Tender will, be adjusted by the PE in accordance with the above procedure for the correction of errors and, with, the concurrence of the Tenderer, shall be considered as binding upon the Tenderer. If the Tenderer does not accept the corrected amount, its Tender will then be rejected, and the Tender Security may be forfeited or the Tender Securing Declaration may be executed in accordance with ITT 18.9 [Tender Security or Bid Securing Declaration].</p>
30. Conversion to Single Currency	30.1	<p>To facilitate evaluation and comparison, the PE will convert all Tender prices expressed in the amounts in various currencies in which the Tender prices are payable to either:</p>

		<ul style="list-style-type: none"> a) in Tanzania Shillings at the selling exchange rate established for similar transactions by the Bank of Tanzania or a commercial bank in the United Republic of Tanzania; or b) a currency widely used in international trade, such as U.S. Dollars, at the selling rate of exchange published in the international press for the amount payable in foreign currency; and at the selling exchange rate established for similar transactions by the Bank of Tanzania in the United Republic of Tanzania for the amount payable in Tanzania Shillings.
	30.2	The currency selected for converting Tender Prices to a common base for the purpose of evaluation, along with the source and date of the exchange rate, are specified in the TDS .
31. Comparison of Tenders	31.1	The PE shall evaluate and compare only the Tenders determined to be substantially responsive in accordance with ITT 28 [Preliminary Examination of Tenders].
	31.2	<p>In evaluating the Tenders, the PE will determine for each Tender the evaluated Tender Price by adjusting the Tender Price as follows: -</p> <ul style="list-style-type: none"> a) making any correction for errors pursuant to ITT 29 [Correction of Errors]; b) excluding provisional sums and the provision, if any, for contingencies in the Bill of Quantities, but including Day work, where priced competitively; c) making appropriate adjustment for any other acceptable variations, deviations, or alternative offers submitted in accordance with ITT 19 [Alternative Tenders by Tenderers]; d) making an allowance for varying times of completion offered by Tenderers, if permitted in the TDS and in the manner prescribed therein; e) making appropriate adjustments to reflect discounts or other price modifications offered in accordance with ITT 24.4 [Modification and Withdrawal of Tenders]; and f) applying any discounts offered by the Tenderer for the award of more than one Contract, if tendering for

		this Contract is being done concurrently with other contracts (ITT 31.5).
--	--	---

	31.3	The PE may waive any minor informality or nonconformity, which does not constitute a material deviation, provided such waiver does not prejudice or affect the relative standing of any Tenderer. Variations, deviations, and alternative offers and other factors, which are in excess of the requirements of the Tendering Documents or otherwise result in unsolicited benefits for the PE will not be taken into account in Tender Evaluation.
32. National Preference	32.1	Works utilizing this Standard Tendering Document shall be exclusively reserved for local contractors as stated in the TDS .
	32.2	The PE shall, in applying exclusive preference, use the Authority's register of Tenderers and other statutory Professional bodies in United Republic to determine whether or not Tenderers are qualified for exclusive preference.
	32.3	A joint venture, consortium or an association between a foreign and local firm in which the contribution of the local firm in that joint venture or association is greater than seventy-five per cent, shall also be eligible to participate in the exclusive preference scheme.
33. Determination of the Lowest Evaluated Tender	33.1	The Tender with the lowest evaluated price from among those that are eligible, compliant and substantially responsive shall be the lowest evaluated Tender.
34. Post-qualification of Tenderer	34.1	If pre-qualification was not undertaken, post-qualification shall be performed as indicated in the TDS.

	34.2	<p>Where the tender price of the lowest evaluated Tenderer is considered to be abnormally low, the PE shall perform price analysis as part of the post-qualification. The following process shall apply:</p> <p>(a) The PE may reject a tender if the PE has determined that the price in combination with other constituent elements of the tender is abnormally low in relation to the subject matter of the procurement (scope of works or services) and raises concerns as to the ability of the Tenderer that presented that tender to perform the contract.</p>
		<p>(b) Before rejecting an abnormally low tender, the PE shall: request the Tenderer for an explanation of the tender or of those parts which it considers contribute to the tender being abnormally low; take account of the evidence provided in response to a request in writing; and subsequently verify the tender or parts of the tender being abnormally low.</p> <p>(c) The decision of the PE to reject a tender and reasons for the decision shall be recorded in the procurement proceedings and promptly communicated to the Tenderer concerned;</p> <p>(d) The Accounting Officer (PE) shall seek the approval of the Authority prior to rejecting a tender;</p> <p>(e) Neither the Authority nor the PE shall incur liability solely by rejecting abnormally tender; and</p> <p>An abnormally low tender means, in the light of the PE's estimate and of all the tenders submitted, the tender appears to be abnormally low by not providing a margin for normal levels of profit.</p>
	34.3	<p>The PE will determine to its satisfaction whether the Tenderer that is selected as having submitted the lowest evaluated responsive Tender is qualified to perform the contract satisfactorily, in accordance with the criteria listed in ITT 12.3 [Documents Establishing Eligibility and Qualifications of the Tenderer].</p>

	34.4	The determination will take into account the Tenderer's financial, technical, and production capabilities. It will be based upon an examination of the documentary evidence of the Tenderer's qualifications submitted by the Tenderer, pursuant to ITT 12.3 [Documents Establishing Eligibility and Qualifications of the Tenderer], as well as such other information as the PE deems necessary and appropriate. Factors not included in these Tendering Documents shall not be used in the evaluation of the Tenderers' qualifications.
	34.4	A PE may seek independent references of a Tenderer and the results of reference checks may be used in determining award of contract.

	34.5	In case of a foreign company, a PE shall seek independent reference of legal existence of a Tenderer from Tanzania diplomatic missions abroad or from any other reliable source.
	34.6	An affirmative determination will be a prerequisite for award of the contract to the Tenderer. A negative determination will result in rejection of the Tenderer's Tender, in which event the PE will proceed to the next lowest evaluated Tender to make a similar determination of that Tenderer's capabilities to perform satisfactorily.
		F. Award of Contract
35. Criteria of Award	35.1	Subject to ITT 34 [Post-qualification of Tenderer] and 36 [Negotiations], the PE will award the Contract to the Tenderer whose Tender has been determined to be substantially responsive to the Tendering Documents and who has offered the lowest Evaluated Tender Price, provided that such Tenderer has been determined to be (a) eligible in accordance with the provisions of ITT 3 [Eligible Tenderers], and (b) is determined to be qualified to perform the Contract satisfactorily (c) successful negotiations have been concluded.

	35.2	If, pursuant to ITT 13.1 [Slice and Package], this Contract is being let on a slice and package" basis, the lowest evaluated Tender price will be determined when evaluating this Contract in conjunction with other Contracts to be awarded concurrently, taking into account any discounts offered by the Tenderers for award of more than one Contract.
36. Negotiations	36.1	<p>Negotiations may be undertaken with the lowest evaluated Tender relating to the following areas:</p> <ul style="list-style-type: none"> (a) a minor alteration to the technical details of the statement of requirements; (b) reduction of quantities for budgetary reasons, where the reduction is in excess of any provided for in the solicitation documents; (c) a minor amendment to the special conditions of Contract; (d) finalizing payment arrangements;
		<ul style="list-style-type: none"> (e) mobilization arrangements; (f) agreeing final delivery or work schedule to accommodate any changes required by the PE; (g) the methodology or staffing; or (h) clarifying details that were not apparent or could not be finalized at the time of tendering. (i) Reduction of price
	36.3	Where negotiation fails to result into an agreement, the PE may invite the next ranked Tenderer for negotiations. Where negotiations are commenced with the next ranked Tenderer, the PE shall not reopen earlier negotiations.
37. PE's Right to accept any Tender and to reject any or all Tenders	37.1	Notwithstanding ITT 35 [Criteria of Award], the PE reserves the right to accept or reject any Tender, and to cancel the tendering process and reject all Tenders, at any time prior to the award of Contract, without thereby incurring any liability to the affected Tenderer or Tenderers or any obligation to inform the affected Tenderer or Tenderers.

	37.2	Notice of the rejection of all Tenders shall be given promptly to all Contractors that have submitted Tenders.
	37.3	The PE shall upon request communicate to any Tenderer the grounds for its rejection of its Tenders, but is not required to justify those grounds.
38. Procuring Entities Right to Vary Quantities at the Time of Award	38.1	The PE reserves the right at the time of contract award to increase or decrease the quantity of goods or related services originally specified in these Tendering Documents (schedule of requirements) provided this does not exceed by the percentage indicated in the TDS , without any change in unit price or other terms and conditions of the Tender and Tendering Documents.
39. Notification of Award	39.1	Prior to awarding of the contract, the PE shall issue a notice of intention to award the contract to all tenderers who participated in the tender in question giving them seven (7) working days within which to submit complaints to the PE thereof, if any.
	39.2	Where no complaints have been lodged, the Tenderer whose Tender has been accepted will be notified of the
		award by the PE prior to expiration of the Tender validity period in writing or electronic forms that provide record of the content of communication. The Letter of Acceptance will state the sum that the PE will pay the successful Tenderer in consideration for the execution of the scope of works as prescribed by the Contract (hereinafter and in the Contract called the "Contract Price).
	39.3	The notification of award will constitute the formation of the Contract, subject to the Tenderer furnishing evidence of registration with relevant statutory bodies within the country and furnishing the Performance Security in accordance with ITT 41 [Performance Security] and signing the Contract in accordance with ITT 40.2 [Signing of Contract]

	39.4	Upon the successful Tenderer's furnishing of the performance security pursuant to ITT 41 [Performance Security], the PE will promptly notify unsuccessful Tenderers, the name of the winning Tenderer and the Contract amount and will discharge the Tender security or Tender securing declaration of the unsuccessful Tenderers pursuant to ITT 18.7 [Tender Security or Bid Securing Declaration].
	39.5	If, after notification of award, a Tenderer wishes to ascertain the grounds on which its Tender was not selected, it should address its request to the Secretary of the appropriate Tender Board that authorized the award of Contract. The Secretary will promptly respond in writing or electronic forms that provide record of the content of communication to the unsuccessful Tenderer citing grounds for rejection of its Tender without disclosing information about other Tenderers.
40. Signing of Contract	40.1	Promptly after notification of award, PE shall send the successful Tenderer the draft Agreement, incorporating all terms and conditions as agreed by the parties to the contract.
	40.2	Within fourteen (14) working days after fulfillment of all conditions precedent, the successful Tenderer and the PE shall sign the Contract.
41. Performance Security	41.1	Within fourteen (14) working days after receipt of the Letter of Acceptance, the successful Tenderer shall deliver to the PE a Performance Security in the amount stipulated in the TDS and SCC , denominated in the type and
		proportions of currencies in the Letter of Acceptance and in accordance with the Conditions of Contract.

	41.2	<p>If the Performance Security is provided by the successful Tenderer, it shall be in the form specified in the TDS which shall be in any of the following:</p> <ul style="list-style-type: none"> (a) cash, certified cheque, cashier's or manager's cheque, or bank draft; (b) irrevocable letter of credit issued by a reputable commercial bank or in the case of an irrevocable letter of credit issued by a foreign bank, the letter shall be confirmed or authenticated by a reputable local bank; (c) bank guarantee confirmed by a reputable local bank or, in the case of a successful foreign Tenderer, bonded by a foreign bank; or (d) surety bond callable upon demand issued by any reputable surety or insurance company. <p>Any Performance Security submitted shall be enforceable in the United Republic of Tanzania.</p>
	41.3	<p>Failure of the successful Tenderer to comply with the requirements of ITT 41.1 shall constitute sufficient grounds for cancellation of the award and any other remedy the PE may take under the Contract and the PE may resort to awarding the Contract to the next ranked Tenderer.</p>
42. Advance Payment	42.1	<p>Advance Payment is not acceptable</p>
	42.2	<p>The Advance Payment request shall be accompanied by an Advance Payment Security (Guarantee) in the form provided in Section IX. For the purpose of receiving the Advance Payment, the Tenderer shall make an estimate of, and include in its Tender, the expenses that will be incurred in order to commence work. These expenses will relate to the purchase of equipment, machinery, materials, and on the engagement of labor during the first month beginning with the date of the PE's "Notice to Commence" as specified in the SCC.</p>
43. Adjudicator	43.1	<p>In the event of dispute, the Adjudicator shall be appointed by the Appointing Authority named in the TDS at the request of either party.</p>
44. Fraudulent, Corrupt, Coercive,	44.1	<p>The Government of the United Republic of Tanzania requires that Procuring entities (including beneficiaries of</p>

<p>Collusive or Obstructive Practices</p>	<p>Government funded projects and procurement) as well as Tenderers/Suppliers/Contractors under Government financed contracts, observe the highest standard of ethics during the procurement and execution of such contracts. In pursuance of this policy, the Government.</p> <p>a) defines, for the purpose of this provision, the terms set forth below as follows: -</p> <ul style="list-style-type: none"> i. "Corrupt practice" means the offering, giving receiving or soliciting of anything of value to influence the action of a public officer in the procurement process or contract execution; ii. "Coercive practice" means impairing or harming, or threatening to impair or harm directly or indirectly, any party or the property of the party for the purpose of influencing improperly the action or that party in connection with public procurement or in furtherance of corrupt practice or fraudulent practice; iii. collusive practices" means impairing or harming, or threatening to impair or harm directly or indirectly, any part or the property of the Party for the purpose of influencing improperly the action or a part or in connection with public procurement or government contracting or in furtherance of a corrupt practice or a Fraudulent Practice iii) "Fraudulent practice" means a misrepresentation of facts in order to influence a procurement process or the execution of a contract to the detriment of the Government or a public body and includes collusive practices among Tenderers, prior to or after submission designed to establish tender prices at artificial non-competitive levels and to deprive the Government of the benefits of free and open competition; iv) "Obstructive practice" means acts intended to materially impede access to required information in exercising a duty under this Act; <p>b) Will reject a proposal for award if it determines that the Tenderer recommended for award has engaged</p>
---	--

		<p>in corrupt, coercive, collusive, fraudulent or obstructive practices in competing for the contract;</p> <p>c) In pursuit of the policy defined in ITT 44.1 the Government will cancel the portion of the funds allocated to a contract for goods, works, or services if it at any time determines that corrupt, coercive, collusive, fraudulent obstructive or fraudulent practices were engaged in by representatives of the PE or approving authority or of a beneficiary of the funds furring the procurement or the execution of that contract, without the PE or approving authority having taken timely and appropriate action satisfactory to the Government of the united Republic of Tanzania to remedy the situation;</p> <p>d) Declare a firm ineligible for a period of ten years, to be awarded a public-financed contract if it at any time it determines that the firm has engaged in corrupt, coercive, collusive, fraudulent or obstructive practices in competing for, or in executing, a public - financed contract.</p>
	44.2	The Government of the United Republic of Tanzania reserves the right, where a firm has been found by a foreign country, international organization or other foreign organization to have engaged in corrupt, coercive, collusive, fraudulent or obstructive practices, to declare that such a firm is ineligible, for a period of ten years to be awarded a public financed Contract in the United Republic of Tanzania.
	44.3	The Government of the United Republic of Tanzania will have the right to require that, in contract financed by the Government of the United Republic of Tanzania a provision be included requiring suppliers and contractors to permit the Government of the United Republic of Tanzania to inspect their accounts and records relating to the performance of the contract and to have them audited by auditors appointed by the Government of the United Republic of Tanzania.
	44.4	Any communications between the Tenderer and the PE related to matters of alleged corruption, coercion, collusion,

		fraudulent or obstruction practices must be made in writing or electronic forms that provide record of
		the content of communication.
		G. Review of Procurement Decisions
45. Right to Review	45.1	A Tenderer who claims to have suffered or that may suffer any loss or injury as a result of breach of a duty imposed on a PE or an approving authority in the course of these procurement proceedings may seek a review in accordance with the procedure set out under this Section.
46. Time Limit on Review	46.1	The Tenderer shall submit an application for review within seven (7) working days of the Tenderer becoming or should have become aware of the circumstances giving rise to the complaint or dispute.
47. Submission of Applications for Review	47.1	Any application for administrative review shall be submitted in writing or electronic forms that provide record of the content of communication to the Accounting Officer of a PE and a copy shall be served to the Public Procurement Regulatory Authority (PPRA) at the address shown in the TDS in writing or in electronic forms that provide record of the content of communication Tender.

	47.2	<p>The application for administrative review shall include:</p> <ul style="list-style-type: none"> a) details of the procurement requirements to which the complaint relates; b) details of the provisions of the Act, Regulation or provision that has been breached or omitted; c) an explanation of how the provisions of the Act, Regulation or provision has been breached or omitted, including the dates and name of the responsible public officer, where known; d) documentary or other evidence supporting the complaint where available; e) remedies sought; and f) any other information relevant to the complaint.
	47.3	<p>The head of a PE shall not entertain a complaint or dispute or continue to do so after the procurement contract has entered into force.</p>
48. Decision by the Head of PE	48.1	<p>The head of a PE shall, within seven (7) working days after receipt of the complaint or dispute, deliver a written decision which shall indicate:</p> <ul style="list-style-type: none"> a) whether the application is upheld in whole, in part or rejected; b) the reasons for the decision; and c) any corrective measures to be taken.
	48.2	<p>Where the head of a PE does not issue a decision within the time specified in ITT 48.1, the Tenderer submitting the complaint or dispute or the PE shall be entitled to institute proceedings under ITT 49.1 [Review by the Public Procurement Appeals Authority (PPAA)] within seven (7) working days after such specified time and upon instituting such proceedings, the competence of the head of a PE to entertain the complaint or dispute shall cease.</p>

<p>49. Review by the Public Procurement Appeals Authority (PPAA)</p>	<p>49.1</p>	<p>Complaints or disputes which,</p> <ul style="list-style-type: none"> (a) are not settled within the specified period under ITT 48.1 [Decision by the Head of PE]; (b) the tenderer is not satisfied with the decision of the accounting officer; or (c) arise after the procurement contract has entered into force pursuant to ITT 40 [Signing of Contract], <p>shall be referred to the Appeals Authority within seven (7) working days from the date when the Tenderer received the decision of the accounting officer or, in case no decision is issued after the expiry of the time stipulated under ITT 47.1 [Submission of Applications for Review] or when the Tenderer become aware or ought to have become aware of the circumstances giving rise to the complaint or dispute pursuant to ITT 46.1 [Time Limit on Review]</p>
	<p>49.2</p>	<p>PPAA may be contacted at the address shown in the TDS.</p>

SECTION III: TENDER DATA SHEET

Tender Data Sheet (TDS)

The following specific data for the works to be procured shall complement, supplement, or amend the provisions in the Instructions to Tenderers (ITT). Whenever there is a conflict, the provisions herein shall prevail over those in ITT.

TDS Clause Number	ITT Number	Amendments of, and Supplements to, Clauses in the Instruction to Tenderers
A. Introduction		
1.	1.1 & 2.1	The PE is: Good Neighbors Tanzania
2.	1.1	Name of Project is: <i>RENOVATION OF CLASSROOMS AND OFFICE AT UHELELA PRIMARY SCHOOL, SUPPORTING BUILDING MATERIALS FOR CONSTRUCTION OF INCINERATOR, ASH PIT AND PLACENTA PIT AT MKAKATIKA DISPENSARY, BAHI -DODOMA REGION</i>
3.	1.2	The expected completion date of the works is: 90 Calendar Days
4.	2.1	Name of financing institution is: Good Neighbors Tanzania Financial Year; 2024/2025 <i>Renovation of classrooms and office at Uhelela Primary School, supporting building materials for construction of incinerator, ash pit and Placenta pit at Mkakatika dispensary, Bahi -Dodoma Region</i>
5.	2.2	The loan/ credit number is: [N/A] and name of the financing Institution Good Neighbor Tanzania
6.	3.1	Maximum number of members in the joint venture, consortium or association shall be: N/A Only Tenderers registered as Building and/or civil Contractors in Class Seven (VII) and above with the Contractors Registration Board are eligible.
7.	6.3	Pre-tender meeting shall not be held.

B. Tendering Documents

8.	7.2	The number of copies to be completed and returned with the tender is: Three (3) .
9.	8.1	Email Address for clarification of Tendering Document is HOlogistics@goodneighbors.or.tz

C. Preparation of Tenders

10.	10.1	Language of Tender and all correspondence shall be English
11	11.1h	Other information or materials required to be completed and submitted by Bidders: a) Sources of materials which meet specifications (esp. Aggregates, blocks) b) Site Organization c) Method statement
12.	12.4	In the case of joint venture, consortium or association each partner shall submit information required under Clause ITT 12.4. In addition, the Tenderer shall furnish the following; Not Applicable
13	15.3	List all duties, taxes and other levies payable by the Contractor under the Contract a) Applicable Taxes
14.	15.4	The price shall be Fixed
15.	16.1	The currency in which the prices shall be quoted shall be: Tanzanian Shillings
16.	16.2	The authority for establishing the rates of exchange shall be Bank of Tanzania. N/A
17.	17.1	The Tender validity period shall be ninety (90) days .
18.	18.1	Bid Securing Declaration is applicable
19.	18.3 & 18.3 c	The Tender Security shall be in the form of: Bid Securing Declaration
20.	19.1	Alternative Tenders are not allowed in this Tender.
21.	19.2	Alternative time for completion Not applicable
22	19.3	Offer of technical alternatives to the requirements of the Tendering Documents are not allowed in this Tender.

23.	20.1	In addition to the original of the Tender, the Tenderer should submit three (3) copies of the Tender.
24.	20.2	Written confirmation of authorization to sign on behalf of the Tenderer is Registered Special Power of Attorney

D. Submission of Bids

25.	21.2 a)	Tenders shall be submitted to: Good Neighbors Tanzania, Head Office Dar es Salaam
26.	21.2 b)	Project name: <i>Renovation of classrooms and office at Uhelela primary school, supporting building materials for construction of incinerator, ash pit and Placenta pit at Mkakatika dispensary, Bahi - Dodoma region</i> <u>Tender title and number: Bid No. GNTZ/HO/011/2024</u>
27.	22.1	The deadline for Tender submission is a) Day: Wednesday b) Date: 21st August, 2024 c) Time: 10:00 am
28.	22.3	The extension of the deadline for submission of Tenders shall be made not later than Seven (7) days before the expiry of the original deadline.

E. Opening and Evaluation of Tenders

29.	25.1	The Tender opening shall take place at: Good Neighbors Tanzania Head Office, Dar es Salaam
30	30.2	The currency that shall be used for tender evaluation and comparison purposes to convert all Tender Prices expressed in various currencies into a single currency is: _____
		The source of exchange rate shall be: N/A The date for the exchange rate shall be: N/A
31.	32.1	Works has been exclusively reserved for Local Contractors registered by the Authority and other statutory bodies in Tanzania.
32	34.1	post-qualification shall be performed or not performed N/A
33.	38.1	Percentage for quantities increase or decrease is limited to fifteen percent 10% when necessary.

F. Award of Contract

34.	41.1	The amount of Performance Security shall be 10% of the Contract price.
35.	41.2	The Performance Security shall be in the form of: Performance Bond
36.	42.1	The Advance Payment: N/A
37.	43.1	The Adjudicator for the project shall be appointed by the Appointing Authority which shall be NCC Tanzania.

G. Right to Review

38.	47.1	<p>The address to submit copies of complaints:</p> <p>The Chief Executive Officer, Public Procurement Regulatory Authority PSPF Dodoma Plaza, 9th Floor, Jakaya Kikwete Road, P.O. Box 2865,</p>
		<p>Dodoma, TANZANIA. Tel: +255 26 2963854 E-mail: ceo@ppra.go.tz Web: www.ppra.go.tz</p>
39.	49.2	<p>The address for Appeal to PPAA:</p> <p>The Executive Secretary, Public Procurement Appeals Authority, Ministry of Finance and Planning, 1 Madaraka Street, P.O. Box 9310, 11468 Dar es Salaam. Telephone +255 22 2120451 Mobile: +255743505505 Fax + 255 022 2120460 Email: info@ppaa.go.tz or es@ppaa.go.tz Website www.ppaa.go.tz</p>

SECTION IV: GENERAL CONDITIONS OF CONTRACT

Table of Clauses

Sec. IV

Contents

SECTION IV: GENERAL CONDITIONS OF CONTRACT	40
Table of Clauses	41
A. General	0
2. Interpretation	4
3. Conditions Precedent	5
4. Language and Law	5
5. Confidentiality.....	5
6. Project Manager's role	5
7. Delegation	5
8. Communications	6
9. Subcontracting	6
10. Assignment	6
11. Liability of Joint Venture	6
12. Other Contractors	6
13. Personnel	7
14. Employer's and Contractor's Risks	7
15. Employer's Risks	8
16. Contractor's Risks	8
17. Insurance	9
18. Site Investigation Reports	9
19. Queries about the Special Conditions of Contract	9
20. Contractor to execute the Works	10
21. Commencement and Completion of the Works	10
22. Approval by the Project Manager	10
23. Protection of the Environment	10
24. Labour Laws	11
25. Taxes and Duties	11
26. Health and Safety	11
27. Discoveries	12
28. Possession of the Site	12
29. Access to the Site	12
30. Instructions, Inspections and Audits	12
31. Disputes	12
32. Procedure for disputes.....	13
33. Fees and Costs of Adjudicator	14
34. Replacement of Adjudicator	14
35. Security of the site.....	14

36	Programme	14
37	Extension of the Intended Completion Date	15
38	Acceleration	16
39	Delays Ordered by the Project Manager	16
40	Management Meetings	16
41	Early Warning Notice	17
42	Identifying Defects	18
41	Tests	18
42	Correction of Defects	18
45	Extension of Defect Liability Period	18
46	Uncorrected Defects	18
47.	D. Cost Control	19
48	Bill of Quantities	19
49.	Changes in the Quantities	19
50	Variations	19
51	Payments for Variations	19
52	Cash Flow Forecasts	19
53	Payment Certificates	20
54	Payments	21
55	Currencies	21
56	Compensation Events	21
57	Effect of Changes in Tax Laws	21
58	Price Adjustment	22.
58	Retention	22
59	Liquidated Damages	23
60.	Bonus	23
61	Advance Payment	23
62	Performance Securities	24
63	Dayworks.....	24
64	Cost of Repairs	24
E.	Discharge of the Contract	24
65	Completion Certificate	25
66	Site Hand Over	25
67	Final Account	25
68	Operating and Maintenance Manuals	25
69	Termination	25
70	Payment upon Termination	28
71	Property	29
72	Suspension of Financing	29
73	Force Majeure	29
74	Release from Performance	30

A. General

1. Definition	<p>The following words and expressions shall have the meanings hereby assigned to them:</p> <p>The Adjudicator is the person appointed by the appointing Authority specified in the Special Conditions of Contract (SCC), to resolve contractual disputes in the first instance, and as provided for in GCC 31 and 32 hereunder.</p> <p>The Arbitrator is the person appointed to resolve contractual disputes, and as provided for in GCC 32 hereunder.</p> <p>Bill of Quantities means the priced and completed Bill of Quantities forming part of the Tender.</p> <p>Compensation Events are those events provided for in GCC 55.</p> <p>The Completion Date is the date of completion of the Works as certified by the Project Manager, in accordance with GCC 21.1</p> <p>The Commencement Date is the date when the Contractor shall commence execution of the Works as specified in the Notice of Contract Commencement. The Commencement Date may be revised by the Project Manager in consultation with the employer by issuing an extension of time.</p> <p>The Contract is the Contract entered between the Employer and the Contractor to execute, complete, and maintain the Works. It consists of the documents listed in GCC 2.3 below.</p> <p>The Contractor is a person whether natural or legal whose Tender to carry out the Works has been accepted by the Employer.</p> <p>The Contractor's Tender is the completed tendering document submitted by the Contractor to the Employer.</p> <p>The Contract Price is the price stated in the Letter of Acceptance and thereafter as adjusted in accordance with the provisions of the Contract.</p> <p>Days are calendar days; Months are calendar</p>
----------------------	--

	<p>months.</p> <p>Dayworks are varied work inputs subject to payment on a time basis for the Contractor’s employees and Equipment, in addition to payments for associated Materials and Plant.</p> <p>A Defect is any part of the Works not completed in accordance with the Contract.</p> <p>The Defects Liability Certificate is the certificate issued by Project Manager upon correction of defects by the Contractor.</p> <p>The Defects Liability Period is the period named in the SCC and calculated from the Completion Date.</p> <p>Drawings means the drawings of the works, as included in the contract and any additional or modified drawings issued by (or on behalf of) the Employer in accordance with the contract.</p> <p>Effective Contract date is the date shown in the notice of Contract Commencement issued by the Employer upon fulfillment of the conditions precedent stipulated in Clause 3 of the GCC.</p> <p>The Employer is the person named as employer in the SCC and the legal successors in title to this person.</p> <p>Equipment is the Contractor’s machinery and vehicles brought to the Site to execute the Works.</p> <p>Force Majeure means an unforeseeable event which is beyond reasonable control of either Party and which makes a Party’s performance of its obligations under the Contract impossible or so impractical as to be considered impossible under the circumstances.</p> <p>For the purposes of this Contract, “Force Majeure” means an event which is beyond the reasonable control of a Party, is not foreseeable, is unavoidable, and its origin is not due to negligence or lack of care on the part of a Party, and which makes a Party’s performance of its obligations hereunder impossible or so impractical as reasonably to be considered impossible in the circumstances; and includes, but is not limited to, war, riots, civil disorder, earthquake,</p>
--	---

	<p>fire, explosion, storm, flood, epidemics, or other adverse weather conditions, strikes, lockouts or other industrial action (except where such strikes, lockouts or other industrial action are within the power of the Party invoking Force Majeure to prevent), confiscation.</p> <p>The Intended Completion Date is the date on which it is intended that the Contractor shall complete the Works. The Intended Completion Date is specified in the SCC. The Intended Completion Date may be revised only by the Project Manager by issuing an extension of time or an acceleration order.</p> <p>Materials are all supplies, including consumables, used by the Contractor for execution of the Works.</p> <p>Plant is any integral part of the Works that shall have a mechanical, electrical, chemical, or biological function.</p> <p>The Project Manager is the person named in the SCC (or any other competent person appointed by the Employer and notified to the Contractor, to act in replacement of the Project Manager) who is responsible for supervising the execution of the Works and administering the Contract.</p> <p>The Site is the area where works are to be executed as specified in the SCC.</p> <p>Site Investigation Reports are factual and interpretative reports about the surface and subsurface conditions at the Site that were included in the Tendering documents as indicated in the SCC.</p> <p>Specification means the Specification of the Works included in the Contract and any modification or addition made or approved by the Project Manager.</p> <p>The Start Date is given in the SCC. It is the latest date when the Contractor shall commence execution of the Works. It does not necessarily coincide with any of the Site Possession Dates.</p> <p>A Subcontractor is a person whether natural or legal who has a Contract with the Contractor to carry out a part of the work in the Contract, which</p>
--	--

	<p>includes work on the Site.</p> <p>Temporary Works are works designed, constructed, installed, and removed by the Contractor that are needed for construction or installation of the Works.</p> <p>A Variation is an instruction given by the Project Manager in consultation with the Employer, that varies the Works.</p> <p>The Works are what the Contract requires the Contractor to construct, install, and turn over to the Employer, as defined in the SCC.</p>
--	---

<p>2. Interpretation</p>	<p>2.1 In interpreting these Conditions of Contract headings and marginal notes are used for convenience only and shall not affect their interpretations unless specifically stated; references to singular include the plural and vice versa; and masculine include the feminine. Words have their ordinary meaning under the language of the Contract unless specifically defined.</p> <p>2.2 If sectional completion is specified in the SCC, references in the Conditions of Contract to the Works, the Completion Date, and the Intended Completion Date apply to any Section of the Works (other than references to the Completion Date and Intended Completion Date for the whole of the Works).</p> <p>2.3 The documents forming the Contract shall be interpreted in the following order of priority:</p> <ol style="list-style-type: none"> (1) Form of Agreement, (2) Special Conditions of Contract, (3) General Conditions of Contract, (4) Letter of Acceptance, (5) Certificate of Contract Commencement, (6) Specifications, (7) Drawings, (8) Bill of Quantities, (9) Contractor's Tender, and (10) Any other document listed in the Special Conditions of Contract as forming part of the Contract.
---------------------------------	---

<p>3. Conditions Precedent</p>		<p>3.1 Having signed the Contract, it shall come into effect on the date on which the following conditions have been satisfied: -</p> <ul style="list-style-type: none"> a) Submission of performance Security in the form specified in the SCC; and b) Furnishing of Unconditional Advance Payment Guarantee. <p>3.2 If the Conditions precedent stipulated on GCC 3.1 is not met by the date specified in the SCC this contract shall not come into effect;</p> <p>3.3 If the Employer is satisfied that each of the conditions precedent in this contract has been satisfied (except to the extent waved by him, but subject to such conditions as he shall impose in respect of such waiver)he shall promptly issue to the contractor a certificate of Contract commencement, which shall confirm the start date.</p>
<p>4. Language and Law</p>		<p>4.1 The language of the Contract and the law governing the Contract are stated in the SCC.</p>
<p>5. Confidentiality</p>		<p>5.1 The Service Providers, their Subcontractors, and the Personnel of either of them shall not disclose any proprietary or confidential information relating to the Project, the Services, this Contract, or the Employer's business or operations without the prior written consent of the Employer.</p>
<p>6. Project Manager's role</p>		<p>6.1 Except where otherwise specifically stated, the Project Manager will supervise execution of the contract between the Employer and the Contractor. The Project Manager shall have no authority to amend the contract.</p>
<p>7. Delegation</p>		<p>7.1 The Project Manager may upon prior consent of the employer and after notifying the contractor, delegate any of his duties and responsibilities to other people except to the Adjudicator, and may cancel any delegation after notifying the Contractor.</p>

8. Communications		8.1 Communications between the Parties to the Contract shall be effective only when in writing whether in hard or electronic form that provides record of the content of the communication. A notice shall be effective only when it is delivered at the address specified in the SCC.
9. Subcontracting		9.1 The Contractor may subcontract with the approval of the Project Manager, subject to consultation with the Employer. Subcontracting shall not alter the Contractor's obligations.
10. Assignment		10.1 The Contractor shall not assign, transfer, pledge or make other disposition of this Contract or any part thereof, or any of the Contractor's rights, claims or obligations under this Contract except with the prior written consent of the Employer.
11. Liability of Joint Venture		<p>11.1 If the Contractor constitutes a joint venture, consortium or other unincorporated grouping of two or more persons:</p> <ul style="list-style-type: none"> (a) These persons shall be jointly and severally liable to the Employer for the performance of the Contract; (b) These persons shall notify the Employer of their leader who shall have the authority to bind the Contractor and each of these persons; and (c) The Contractor shall not alter its composition or legal status without the prior consent of the Employer.
12. Other Contractors		12.1 The Contractor shall cooperate and share the Site with other contractors, public authorities, utilities, and the Employer between the dates given in the Schedule of Other Contractors, as referred to in the SCC. The Contractor shall also provide facilities and services for them as described in the Schedule. The Employer may modify the Schedule of Other Contractors, and shall notify the Contractor of any such modification

<p>13. Personnel</p>		<p>13.1 The Contractor shall employ the key personnel named in the Schedule of Key Personnel, as referred to in the SCC, to carry out the functions stated in the Schedule or other personnel approved by the Project Manager. The Project Manager will approve any proposed replacement of key personnel only if their relevant qualifications and abilities are substantially equal to or better than those of the personnel listed in the Schedule.</p> <p>13.2 If the Project Manager asks the Contractor to remove a person who is a member of the Contractor's staff or work force, stating the reasons for, the Contractor shall ensure that the person leaves the Site within seven days and has no further connection with the work in the Contract.</p>
<p>14. Employer's and Contractor's Risks</p>		<p>14.1 The Employer carries the risks which this Contract states are Employer's risks, and the Contractor carries the risks which this Contract states are Contractor's risks.</p>

<p>15. Employer's Risks</p>	<p>15.1 From the Start Date until the Defects Correction Certificate has been issued, the following are Employer's risks:</p> <ul style="list-style-type: none"> (a) The risk of personal injury, death, or loss of or damage to property (excluding the Works, Plant, Materials, and Equipment), which are due to <ul style="list-style-type: none"> (i) use or occupation of the Site for the purpose of the Works, which is the unavoidable result of the Works or (ii) negligence, breach of statutory duty, or interference with any legal right by the Employer or by any person employed by or contracted to him except the Contractor. (b) The risk of damage to the Works, Plant, Materials, and Equipment to the extent that it is due to a fault of the Employer or in the Employer's design, <p>15.2 From the Completion Date until the Defects Correction Certificate has been issued, the risk of loss of or damage to the Works, Plant, and Materials is an Employer's risk except loss or damage due to</p> <ul style="list-style-type: none"> (i) a Defect which existed on the Completion Date, (ii) an event occurring before the Completion Date, which was not itself an Employer's risk, or (ii) the activities of the Contractor on the Site after the Completion Date.
<p>16. Contractor's Risks</p>	<p>16.1 From the Starting Date until the Defects Correction Certificate has been issued, the risks of personal injury, death, and loss of or damage to property (including, without limitation, the Works, Plant, Materials, and Equipment) which are not Employer's risks are Contractor's risks.</p>

<p>17. Insurance</p>		<p>17.1 The Contractor shall provide, in the joint names of the Employer and the Contractor, insurance cover from the Start Date to the end of the Defects Liability Period, in the amounts and deductibles stated in the SCC for the following events which are due to the Contractor's risks:</p> <ul style="list-style-type: none"> (a) loss of or damage to the Works, Plant, and Materials; (b) loss of or damage to Equipment; (c) loss of or damage to property (except the Works, Plant, Materials, and Equipment) in connection with the Contract; and (d) personal injury or death. <p>17.2 Policies and certificates for insurance shall be delivered by the Contractor to the Project Manager for the Project Manager's approval before the Start Date. All such insurance shall provide for compensation to be payable in the types and proportions of currencies required to rectify the loss or damage incurred.</p> <p>17.3 If the Contractor does not provide any of the policies and certificates required, the Employer may affect the insurance which the Contractor should have provided and recover the premiums the Employer has paid from payments otherwise due to the Contractor or, if no payment is due, the payment of the premiums shall be a debt due.</p> <p>17.4 Alterations to the terms of insurance shall not be made without the approval of the Project Manager.</p> <p>17.5 Both parties shall comply with any conditions of the insurance policies.</p>
<p>18. Site Investigation Reports</p>		<p>18.1 The Contractor shall, in executing the contract, rely on Site Investigation Reports referred to in the SCC and any supplemented information available to the Contractor.</p>
<p>19. Queries about Implementation of Contract</p>		<p>19.1 The Project Manager will clarify queries on all contractual matters.</p>

<p>20. Contractor to execute the Works</p>		<p>20.1 The Contractor shall execute and install the Works in accordance with the Terms and Conditions of Contract.</p>
<p>21. Commencement and Completion of the Works</p>		<p>21.1 The Contractor may commence execution of the Works on the Start Date and shall carry out the Works in accordance with the Works Programme submitted by the Contractor, as updated with the approval of the Project Manager, and complete them by the Intended Completion Date.</p>
<p>22. Approval by the Project Manager</p>		<p>22.1 The Contractor shall submit Specifications and Drawings showing the proposed Temporary Works to the Project Manager, who is to approve them if they comply with the Specifications and Drawings.</p> <p>22.2 The Contractor shall be responsible for design of Temporary Works.</p> <p>22.3 The Project Manager's approval shall not alter the Contractor's responsibility for design of the Temporary Works.</p> <p>22.4 The Contractor shall obtain approval of third parties to the design of the Temporary Works, where required.</p> <p>22.5 All Drawings prepared by the Contractor for the execution of the temporary or permanent Works, are subject to prior approval by the Project Manager before their use.</p>
<p>23. Protection of the Environment</p>		<p>23.1 The Contractor shall take all reasonable steps to protect the environment and to limit damage and nuisance to people and property resulting from pollution, noise and other results of his operations.</p>
		<p>23.2 The Contractor shall ensure that emissions, surface discharges and effluent from his activities shall not exceed limits prescribed in relevant environmental laws.</p>

24. Labor Laws		<p>24.1 The Contractor shall comply with all the relevant labor laws applicable in the Country, including laws relating to workers' employment, working hours, health, safety, welfare, immigration and shall allow them all their legal rights.</p> <p>24.2 The Contractor shall require his employees to obey all applicable laws, including those concerning safety at work.</p>
25. Taxes and Duties		<p>25.1 The Contractor, Sub-contractors and Personnel shall pay such taxes, duties, fees and other impositions as may be levied under the Laws of Tanzania unless otherwise stated in the SCC.</p>
26 Health and Safety		<p>26.1 The Contractor shall at all times take all reasonable precautions to maintain the health and safety of his personnel and the public as per the governing occupational, health and safety laws.</p>
		<p>26.2 The Contractor shall ensure that first aid facilities are available at all times at the site and that suitable arrangements are made for all necessary welfare and hygiene requirements and for the prevention of epidemics.</p> <p>26.3 The Contractor shall notify the Employer details of any accident as soon as practicable after its occurrence. The Contractor shall maintain records and make reports concerning health, safety, and welfare of persons, and damage to the property, as the Employer may reasonably require.</p> <p>26.4 The Contractor shall conduct an HIV-Aids awareness programme, and shall take other such measures as specified in the SCC to reduce the risk of transfer of HIV virus between and among Contractor personnel, the Employers Staff and the surrounding community.</p>

27 Discoveries		27.1 Anything of historical or other interest or of significant value unexpectedly discovered on, in, or under the land at the Site shall be the property of the Employer. The Contractor shall notify the Project Manager of such discoveries and carry out the Project Manager's instructions for dealing with them.
28 Possession of the Site		28.1 The Employer may give possession of whole or parts of the Site to the Contractor as stated in the SCC.
29 Access to the Site		29.1 The Contractor shall allow the Project Manager and any person authorized by the Project Manager access to the Site and to any place where work in connection with the Contract is being carried out or is intended to be carried out.
30 Instructions, Inspections and Audits		<p>30.1 The contractor shall comply with instructions given by the Project Manager in writing on any matter related to the contract which comply with the applicable laws where the Site is located.</p> <p>30.2 The Contractor shall permit the Government of the United Republic of Tanzania to inspect the Contractor's accounts and records relating to the performance of the Contractor and to have them audited by auditors appointed by the Government of the United Republic of Tanzania, if so required by the Government of the United Republic of Tanzania</p>
31 Disputes Resolution		31. 1 In the event of any dispute arising out of this contract, either party shall issue a notice of dispute to settle the dispute amicably. The parties hereto shall, within twenty eight (28) days from the notice date, use their best efforts to settle the dispute amicably through mutual consultations and negotiation. Any unsolved dispute may be referred by either party to an adjudicator nominated by the appointing Authority specified in SCC.

<p>32 Procedure for disputes</p>		<p>32.1 After the dispute has been referred to the adjudicator, within 30 days, or within such other period as may be proposed by the Parties, the Adjudicator shall give its decision. The rendered decision shall be binding to the Parties.</p> <p>32.2 If either Party is dissatisfied with the Adjudicator's decision may, within days specified in the SCC refer the dispute for arbitration. If either party within the period mentioned in the SCC has not referred the matter for arbitration the decision shall become final and binding to the Parties.</p>
		<p>32.3 The arbitration shall be conducted in accordance with the arbitration procedure published by the institution named and in the place shown in the SCC.</p>

33 Fees and Costs of Adjudicator		33.1 The rate of the Adjudicator’s fee and administrative costs of adjudication shall be borne equally by the Parties. The rates and costs shall be in accordance with the rules of the Appointing Authority. In conducting adjudication to its finality each party shall bear its incurred costs and expenses.
34 Replacement of Adjudicator		34.1 Should the Adjudicator resign or die, or should the Employer and the Contractor agree that the Adjudicator is not functioning in accordance with the provisions of the Contract; a new Adjudicator will be appointed by the Appointing Authority.
35 Security of the Site		<p>35.1 Unless otherwise stated in the SCC,</p> <ul style="list-style-type: none"> (a) the Contractor shall be responsible for keeping un-authorized persons off the site, and (b) authorized persons shall be limited to the Contractor’s and Employer’s personnel, and to any other personnel and other Contractor notified to the Contractor by the Project Manager or Employer.
		B. Time Control
36 Programme		36.1 Within the time stated in the SCC, the Contractor shall submit to the Project Manager for approval of a Work Programme showing the method(s), arrangements, order, and timing for all the activities of the Works.
		36.2 The Contractor shall submit to the Project Manager for approval an updated Works Program at intervals not longer than the period stated in the SCC. If the Contractor does not submit an updated Works Program within this period, the Project Manager may withhold the amount stated in the SCC from the next payment certificate and continue to withhold this amount until the next payment after the date on which the overdue Program has been submitted.

		36.3 An update of the Works Program shall be a program showing the actual progress achieved on each activity and the effect of the progress achieved on the timing of the remaining work, including any changes to the sequence of the activities.
		36.4 The Project Manager's approval of the Programme shall not alter the Contractor's obligations. The Contractor may revise the Programme and submit it to the Project Manager again at any time. A revised Programme shall show the effect of Variations and Compensation Events
37 Extension of the Intended Completion Date		37.1 The Employer may extend the Intended Completion Date if a Compensation Event occurs or a Variation is issued which makes it impossible for Completion to be achieved by the Intended Completion Date without the Contractor taking steps to accelerate the remaining work, which would cause the Contractor to incur additional cost.
		37.2 The Employer shall, within seven (7) days of receipt of application for extension of the Intended Completion Date by the Contractor, decide whether or not to grant the extension. The application by the Contractor shall be granted only when supported by full information of a compensation event(s) or variation.
		37.3 In the event the Contractor has not issued an early warning notice of a delay or has failed to cooperate in dealing with a delay, such a delay or failure may be a ground for not granting the extension of the Intended Completion Date

<p>38 Acceleration</p>		<p>38.1 When the Employer wants the Contractor to finish the works before the Intended Completion Date, the Project Manager will obtain priced proposals for achieving the necessary acceleration from the Contractor. If the Employer accepts the said proposals, the Intended Completion Date will be adjusted accordingly and confirmed by both the Employer and the Contractor.</p> <p>38.2 In the event that the Contractor's priced proposals for an acceleration of the Works are accepted by the Employer, they shall be incorporated in the Contract Price and treated as a Variation.</p>
<p>39 Delays Ordered by the Project Manager</p>		<p>39.1 The Project Manager may instruct the Contractor to delay the start or progress of any activity within the Works</p> <p>39.2 During such suspension, the Contractor shall protect, store and secure such part or the Works against any deterioration, loss or damage.</p> <p>39.3 The Project Manager may also notify the cause for the suspension.</p>
<p>40 Management Meetings</p>		<p>40.1 Either the Project Manager or the Contractor may require the other to attend a management meeting. The business of a management meeting shall be to review the plans for remaining work and to deal with matters raised in accordance with the early warning procedure.</p> <p>40.2 The Project Manager shall record the business of management meetings and provide copies of the record to those attending the meeting and to the Employer. The responsibility of the parties for actions to be taken shall be decided by the Project Manager either at the management meeting or after the management meeting and stated in writing to all who attended the meeting.</p>

<p>41 Early Warning Notice</p>		<p>41.1 The Contractor shall warn the Project Manager at the earliest opportunity of specific likely future event(s) or circumstance(s) that may adversely affect the quality of the Works, increase the Contract Price or delay the execution of the Works. Upon receipt of the said Notice, the Project Manager may require the Contractor to provide an estimate of the expected effect of the future event(s) or circumstance(s) on the Contract Price and Intended Completion Date or Completion Date as the case may be. The estimate shall be provided by the Contractor as soon as reasonably possible.</p> <p>41.2 The Contractor shall cooperate with the Project Manager in making and considering proposals for how the effect of such an event(s) or circumstance(s) can be avoided or reduced by anyone involved in the Works and in carrying out any resulting Instruction of the Project Manager.</p>
		<p>C. Quality Control</p>

<p>42 Identifying Defects</p>		<p>42.1 The Project Manager shall check the Contractor’s work and notify the Contractor of any Defects that are found. Such checking shall not affect the Contractor’s responsibilities.</p> <p>42.2 The Project Manager may instruct the Contractor to search for a Defect and to uncover and test any work that the Project Manager considers may have a Defect.</p>
<p>43 Tests</p>		<p>43.1 The Project Manager may instruct the Contractor to carry out a test not specified in the Specification to check whether any work has a Defect and in the event the test shows that it does, the Contractor shall pay for the test and any samples thereof. If there is no Defect, the test shall be a Compensation Event.</p>
<p>44 Correction of Defects</p>		<p>44.1 The Project Manager shall give notice to the Contractor of any Defects before the end of the Defects Liability Period stated in the SCC, which begins from the Completion date.</p> <p>44.2 Every time notice of a Defect is given, the Contractor shall correct the notified Defects within the period of time specified in the Project Manager’s notice.</p> <p>44.3 If the Contractor has not corrected a defect within the time specified in the Employer’s notice, a penalty for lack of performance will be paid by the Contractor. The amount to be paid will be calculated as a percentage of the cost of having the defect correct, assessed as described in GCC 46.1.</p>
<p>45 Extension of Defect Liability Period</p>		<p>45.1 The Defects Liability Period may be extended by the Project Manager for as long as Defects remain to be corrected.</p>
<p>46 Uncorrected Defects</p>		<p>46.1 In the event the Contractor has not corrected a Defect(s) within the time specified in the Project Manager’s notice, the Project Manager will assess the cost of having the Defect corrected, including any other related cost(s) and the Contractor will pay the said cost.</p>

		D. Cost Control
47 Bill of Quantities		<p>47.1 The Bill of Quantities shall contain items for the construction, installation, testing, and commissioning work to be done by the Contractor.</p> <p>47.2 The Bill of Quantities is used to calculate the Contract Price. The Contractor shall be paid for the quantity of the work done at the rate in the Bill of Quantities for each item.</p>
48 Changes in the Quantities		<p>48.1 If the final quantity of the work done differs from the quantity in the Bill of Quantities for the particular item by more than 25 percent, provided the change exceeds 1 percent of the Initial Contract Price, the Project Manager shall adjust the rate to allow for the change.</p> <p>48.2 The Project Manager shall not adjust rates from changes in quantities if thereby the Initial Contract Price is exceeded by more than 15 percent, except with the prior approval of the Employer.</p> <p>48.3 If requested by the Project Manager, the Contractor shall provide the Project Manager with a detailed cost breakdown of any rate in the Bill of Quantities.</p>
49 Variations		49.1 All price is FIXED. No variation shall be approved by project manager.
50 Payments for Variations		N/A
51 Cash Flow Forecasts		<p>51.1 When the Works Programme is updated, the Contractor shall provide the Project Manager with an updated cash flow forecast. The cash flow forecast shall include different currencies, as defined in the Contract, converted as necessary using the Contract exchange rates.</p>

<p>52 Payment Certificates</p>	<p>52.1 The Contractor shall submit to the Project Manager monthly statements of the estimated value of the work executed less the cumulative amount certified previously.</p> <p>52.2 The Project Manager shall check the Contractor's monthly statement and certify the amount to be paid to the Contractor within Seven (7) days of receipt of the certificate from the contractor.</p> <p>52.3 The value of work executed shall be determined by the Project Manager.</p> <p>52.4 The value of work executed shall comprise the value of the quantities of the items in the Bill of Quantities completed.</p> <p>52.5 The value of work executed shall include the valuation of Variations and Compensation Events.</p> <p>52.6 The Project Manager may exclude any item certified in a previous certificate or reduce the proportion of any item previously certified in any certificate in the light of later information.</p> <p>52.7 The Project Manager shall not be bound to certify any payment, if the net amount, after all retentions and deductions would be less than minimum amount of Interim Payment Certificate stated in the SCC.</p>
---------------------------------------	--

<p>53 Payments</p>		<p>53.1 Payments shall be adjusted for deductions for advance payments and retention. The Employer shall pay the Contractor the amounts certified by the Project Manager within 7 days of the date of each certificate.</p> <p>53.2 If an amount certified is increased in a later certificate or as a result of an award by the Adjudicator or an Arbitrator, the Contractor shall be paid interest upon the delayed payment as set out in this clause. Interest shall be calculated from the date upon which the increased amount would have been certified in the absence of dispute.</p> <p>53.3 Unless otherwise stated, all payments and deductions will be paid or charged in the proportions of currencies comprising the Contract Price.</p> <p>53.4 Items of the Works for which no rate or price has been entered in will not be paid for by the Employer and shall be deemed covered by other rates and prices in the Contract.</p>
<p>54 Currencies</p>		<p>54.1 The currency of payment shall be stated in the SCC.</p> <p>54.2 Where payments are to be made in currencies other than the Tanzania Shillings, the exchange rates to be used for calculating such amounts shall be the Bank of Tanzania exchange rate prevailing on the date of contract signature</p>
<p>55 Compensation Events</p>		<p>N/A</p>
<p>56 Effect of Changes in Tax Laws</p>		<p>N/A</p>

<p>57 Retention</p>		<p>58.1 The Employer shall retain from each payment due to the Contractor the proportion stated in the SCC. The total amount of retention shall not exceed the amount specified in the SCC.</p> <p>58.2 On completion of the whole Works, half the total amount retained shall be paid to the Contractor and the other half when the Defects Liability Period of six months has passed and the Project Manager has certified that all Defects notified by the Project Manager to the Contractor before the end of this period have been corrected.</p> <p>58.3 On completion of the whole Works, the Contractor may substitute retention money with an “on demand” or unconditional Bank guarantee.</p>
----------------------------	--	---

<p>58 Liquidated Damages</p>		<p>59.1 The Contractor shall pay liquidated damages to the Employer at the rate per day stated in the SCC for each day that the Completion Date is later than the Intended Completion Date. The total amount of liquidated damages shall not exceed the maximum amount of performance security specified in the SCC. The Employer may deduct liquidated damages from payments due to the Contractor. Payment of liquidated damages shall not affect the Contractor’s liabilities.</p> <p>59.2 If the Intended Completion Date is extended after liquidated damages have been paid, the Project Manager shall correct any overpayment of liquidated damages by the Contractor by adjusting the next payment certificate. The Contractor shall be paid interest on the overpayment, calculated from the date of payment to the date of repayment, at the rates specified in GCC 53.1</p> <p>59.3 Where the Project Manager, after assessment of work progress, upon satisfaction that the Contractor will not complete the works within the contract period, may issue a notice to the Contractor requiring the payment of liquidated damages pursuant to GCC 59.1</p> <p>59.4 If the Contractor has not corrected a defects within the time specified in the Employer’s notice, the Employer will assess the cost of having the defect corrected, the Contractor will pay this amount, and a penalty for lack of performance calculated as described in GCC 46.1</p>
<p>60 Advance Payment</p>		<p>N/A</p>

<p>61 Performance Securities</p>		<p>62.1 The Performance Security shall be provided to the Employer no later than the date specified in the Letter of Acceptance and shall be issued in an amount stated in the SCC and form and by a bank or surety acceptable to the Employer, and denominated in the types and proportions of the currencies in which the Contract Price is payable. The Performance Security shall be valid until a date 28 days from the date of issue of the Certificate of Completion in the case of a Bank Guarantee, and until one year from the date of issue of the Completion Certificate in the case of a Performance Bond.</p>
		<p>62.2 Where circumstances necessitate the amendment of the contract after signature, and such amendment is effected, the Employer shall require the Contractor to provide additional Performance Security to cover for any cumulative increase of more than ten percent of the Initial Contract Price.</p>
<p>62 Day works</p>		<p>63.1 If applicable, the Dayworks rates in the Contractor's Tender shall be used for small additional amounts of work only when the Project Manager has given written instructions in advance for additional work to be paid for in that way.</p> <p>63.2 All work to be paid for as Dayworks shall be recorded by the Contractor on forms approved by the Project Manager. Each completed form shall be verified and signed by the Project Manager within two days of the work being done.</p> <p>63.3 The Contractor shall be paid for Dayworks subject to obtaining signed Dayworks forms.</p>
<p>63 Cost of Repairs</p>		<p>64.1 Loss or damage to the Works or Materials to be incorporated in the Works between the Start Date and the end of the Defects Correction periods shall be remedied by the Contractor at the Contractor's cost if the loss or damage arises from the Contractor's acts or omissions.</p>
		<p>E. Discharge of the Contract</p>

<p>64 Completion Certificate</p>		<p>65.1 The Contractor shall request the Project Manager to issue a certificate of Completion of the Works, and the Project Manager will issue upon satisfaction that the work is completed.</p>
<p>65 Site Hand Over</p>		<p>66.1 When the Certificate of Completion is issued by the Project Manager, the Contractor shall handover the site and the works to the Employer within time specified in the SCC</p>
<p>66 Final Account</p>		<p>67.1 Upon the expiry of the defect liability period, the Contractor shall supply the Project Manager with a detailed account of the total amount that the Contractor considers payable under the Contract. The Project Manager shall, within fifty six (56) days, verify the account and, upon satisfaction, certify any final payment due to the Contractor and thereafter issue a defect liability certificate.</p> <p>67.2 In the event the Project Manager is not satisfied with the Account submitted by the Contractor pursuant to sub-Clause 67.1, shall within 56 days issue a schedule of correction. If the final account remains unsatisfactory after it has been resubmitted, the Project Manager shall, upon consultation with the Employer, decide on the amount payable to the Contractor and issue a payment certificate.</p>
<p>67 Operating and Maintenance Manuals</p>		<p>68.1 The Contractor shall supply to the Employer the "as built" Drawings and/or operating and maintenance manuals and any other related documents by the handover period stipulated in the SCC pursuant to GCC 66</p> <p>68.2 If the Contractor does not supply the Drawings and/or manuals stated in GCC 68.1 by the dates specified pursuant to clause 66 of the GCC, or they do not receive the Project Manager's approval, the Project Manager shall withhold the amount stated in the SCC from payments due to the Contractor.</p>

68 Termination		69.1 The Employer or the Contractor may terminate the Contract if the other party causes a fundamental breach of the Contract.
----------------	--	--

		<p>69.2 Fundamental breaches of Contract shall include, but shall not be limited to, the following:</p> <ul style="list-style-type: none"> (a) the Contractor stops work for 28 days when no stoppage of work is shown on the current Works Programme and the stoppage has not been authorized by the Project Manager; (b) the Project Manager instructs the Contractor in writing to delay the Works progress, and the instruction is not withdrawn in writing within 28 days (c) contractor's failure to submit performance security within the time stipulated in the SCC; (d) the Employer or the Contractor is declared bankrupt or goes into liquidation other than for a reconstruction or amalgamation; (e) a payment certified by the Project Manager is not paid by the Employer to the Contractor after 84 days from the date of the Project Manager's certificate; (f) Failure of the Contractor to correct the defect after lapse of time specified in the notice to correct defects issued by the Project Manager.; (g) where the Contractor fails to furnish and maintain the required Site Security pursuant to GCC 35; and (h) The contractor does not maintain security which is required; and (i) the Contractor has delayed the completion of the Works by the number
--	--	---

		<p>of days for which the maximum amount of liquidated damages can be paid, as defined in the SCC.</p> <p>(j) if the Employer determines, based on the reasonable evidence, that the Contractor has engaged in corrupt, coercive, collusive,</p>
--	--	--

		<p>obstructive or fraudulent practices in competing for or in executing the Contract.</p> <p>For the purpose of this paragraph:</p> <p>“corrupt practice means the offering, giving receiving or soliciting of anything of value to influence the action of a public officer in the procurement process or contract execution;</p> <p>“coercive practice” means impairing or harming, or threatening to impair or harm directly or indirectly, any party or the property of the party for the purpose of influencing improperly the action or that party in connection with public procurement or in furtherance of corrupt practice or fraudulent practice;</p> <p>collusive practices” means impairing or harming, or threatening to impair or harm directly or indirectly, any part or the property of the Party for the purpose of influencing improperly the action or a part or in connection with public procurement or government contracting or in furtherance of a corrupt practice or a Fraudulent Practice</p> <p>“fraudulent practice” means a misrepresentation of facts in order to influence a procurement process or the execution of a contract to the detriment of the Employer and includes collusive practices among tenderers, prior to or after submission designed to establish tender prices at artificial non-competitive levels and to deprive the employer of the benefits of free and open competition;</p> <p>“obstructive practice” means acts intended to materially impede access to required information in exercising a duty under this Contract;</p> <p>69.3 When either party to the Contract gives notice of a Fundamental breach of Contract to the other Party for a cause other than those listed under Sub-Clause 69.2 above, the Project Manager shall decide whether the said breach is</p>
--	--	---

		<p>fundamental or not.</p> <p>69.4 Notwithstanding the above, the Employer may terminate the Contract for convenience.</p> <p>69.5 If the Contract is terminated, the Contractor shall stop work immediately, make the Site safe and secure, and leave the Site as soon as reasonably possible.</p>
69 Payment upon Termination		<p>70.1 If the Contract is terminated because of a fundamental breach of Contract by the Contractor, the Project Manager shall issue a certificate for the value of the work done and Materials ordered less advance payments received up to the date of the issue of the certificate and less the percentage to apply to the value of the work not completed as specified in the SCC. Additional Liquidated Damages shall not apply. If the total amount due to the Employer exceeds any payment due to the Contractor, the difference shall be a debt payable to the Employer.</p>
		<p>70.2 If the Contract is terminated for the Employer's convenience or because of a fundamental breach of Contract by the Employer, the Project Manager shall issue a certificate for the value of the work done, Materials ordered, the reasonable cost of removal of Equipment, repatriation of the Contractor's personnel employed solely on the Works, and the Contractor's costs of protecting and securing the Works, and less advance payments received up to the date of the certificate.</p>
70 Property		<p>71.1 All Materials on the Site, Plant, Equipment, Temporary Works, and Works shall be deemed to be the property of the Employer if the contract is terminated for fundamental breach by the Contractor,</p>

<p>71 Suspension of Financing</p>		<p>72.1 In the event that the source of financing is suspended to the Employer, from which part of the payments to the Contractor are being made:</p> <p>(a) The Employer shall notify the Contractor of such suspension within seven (7) days of having received the financing agency's suspension notice.</p> <p>(b) After the Notice has been issued and within fourteen (14) days, the Parties shall mutually agree on the future events of the Contract</p>
<p>72 Force Majeure</p>		<p>73.1 Neither Party shall have any liability or be deemed to be in breach of the Contract for any delay or other failure in performance of its obligations under the Contract, if such delay or failure is a result of an event of Force Majeure.</p> <p>73.2 For purpose of this clause, "Force Majeure" means an event which is beyond the reasonable control of a Party, is not foreseeable, is unavoidable, and its origin is not due to negligence or lack of care on the part of a Party, and which makes a Party's performance of its obligations hereunder impossible or so impractical as reasonably to be considered impossible in the circumstances, and includes, but is not limited to, war, riots, civil disorder, earthquake, fire, explosion, storm, flood, epidemics, or other adverse weather conditions, strikes, lockouts or other industrial action (except where such strikes, lockouts or other industrial action are within the power of the Party invoking Force Majeure to prevent</p> <p>73.3 If a Party (hereinafter referred to as "the Affected Party") is or will be prevented from performing its substantial obligation under the contract by Force Majeure, it shall give a Notice to the other Party giving full particulars of the event and circumstance of Force Majeure and the reasons for the event of Force Majeure preventing the Affected Party from, or delay the Affected Party</p>

	<p>from performing its obligations under the Contract. The Notice shall be given within fourteen days after the Affected Party becomes aware, or should have become aware, of the relevant event or circumstances constituting Force Majeure;</p> <p>73.4 The Affected Party shall use reasonable efforts to mitigate the effects of the event of Force Majeure and shall endeavor to minimize any delay in the performance of the contract as a result of Force Majeure;</p> <p>73.5 The Affected Party shall give Notice to the other Party when it ceases to be affected by the Force Majeure; and</p> <p>73.6 Upon completion of the event of Force Majeure and issuance Notice pursuant to GCC 73.3 the Affected Party must, as soon as reasonably practicable recommends the performance of its obligations under the contract. Where the Affected Party is the Contractor, the Contractor must provide a revised Work Program rescheduling the Works to minimize the effect of the prevention or delay caused by the event of Force Majeure.</p>
<p>73 Release from Performance</p>	<p>74.1 In the event the Affected Party have used all reasonable efforts to mitigate the effect of the event of force Majeure and minimize any delay in the performance of the contract as result of force Majeure, but the effect of force Majeure still subsist, the Project Manager upon written consent of the employer shall certify that the Contract has been frustrated.</p> <p>Upon certification by the Project Manager pursuant to GCC 74.1 the Contractor shall make the site safe and stop work as quickly as possible after receiving the certificate and shall be paid for all Works carried out.</p>

SECTION V: SPECIAL CONDITIONS OF CONTRACT

Special Conditions of Contract (SCC)

The following Special Conditions of Contract shall supplement the General Conditions of Contract. Whenever there is a conflict, the provisions herein shall prevail over those in the General Conditions of Contract. Except where otherwise indicated, all Special Conditions of Contract should be filled in by the Employer prior to issuance of the Tendering Documents. Schedules and reports to be provided by Employer should be annexed.

SCC Clause	GCC Clause	Description
1	1.1	<p style="text-align: center;">A. General</p> <p>The Employer is Good Neighbors Tanzania P.o. Box 33104 Dar es Salaam</p> <p>The Defects Liability Period is 180 days.</p> <p>The Project Manager is District Engineer P.o. Box 2993 Bahi - Dodoma</p> <p>Renovation Of Classrooms and Office at Uhelela Primary School, Supporting Building Materials For Construction Of Incinerator, Ash Pit And PLACENTA Pit At Mkakatika Dispensary, Bahi -Dodoma Region</p> <p>The Start Date shall be 18th September 2024</p> <p>The Intended Completion Date for the whole of the Works shall be 17th November 2024</p> <p>The Site is located at Uhelela and Mkakatika Village(s), Bahi District, Dodoma Region.</p>
2.	2.2	Indicate whether sectional completion is specified N/A

3.	2.3(10)	List other documents that form part of the contract if any: a) Form of agreement b) Letter of Acceptance c) Contractor's Bid form d) General Condition of Contract e) Special Condition of Contract f) Specifications
		g) Drawings h) Bill of Quantities i) Special Power of Attorney j) Other documents that form part of the Contract.
4.	4.1	The language of the Contract documents is English . The law that applies to the Contract is the Laws of Tanzania.
5	8.1	Address for communication Employer's; HOlogistics@goodneighbors.or.tz Contractor's.....[insert address]
6.	12.1	Include the Schedule of Other Contractors, if any. [N/A]
7.	13.1	Include the Schedule of Key Personnel. <ul style="list-style-type: none"> • 1 Civil Engineer- Minimum 3 years Experiences in supervising building construction works and proven Three completed projects. Registration with ERB • 1 Technician (FTC/Diploma holder, Minimum 3years in building works with minimum five completed Projects. • 2 Site foremen -Minimum 5years experience in building works with minimum five projects supervised and completed. <p>NB: CVs and Education certificates to be attached.</p>

8.	17.1	<p>The minimum insurance covers shall be:</p> <ul style="list-style-type: none"> (a) loss of or damage to the Works, Plant, and Materials <i>[insert amount]</i>; (b) loss of or damage to Equipment <i>[insert amount]</i>; (c) loss of or damage to property (except the Works, Plant, Materials, and Equipment) in connection with the Contract <i>[insert amount]</i>; and (d) Personal injury or death <i>[insert amount]</i>.
9.	18.1	Site Investigation Reports available to the Tenderer are: N/A
	25.1	Unless otherwise state tax payment status.....
10.	26.4	<p>The other measures include:</p> <ul style="list-style-type: none"> a. Minimizing the number of migrant workers employed on the project and household in the site camp b. Providing access to voluntary counseling and testing
		<p>(VCT)</p> <ul style="list-style-type: none"> c. Providing psychological support and health care including prevention and treatment of opportunistic infections for workers infected and affected, as well as their families d. Providing condoms (male and female) to workers
11.	28.1	The Site Possession Date shall be 7 to 14 Days after Contract Signing.
12.	32.2	If either Party is dissatisfied with the Adjudicator's decision may, refer the dispute for arbitration within [14] days
13	31.1	Appointing Authority for the Adjudicator: <i>Good Neighbors Tanzania</i>
14.	q	Arbitration will take place at Good Neighbors Tanzania in accordance with rules and regulations published by Government of United Republic of Tanzania <i>using PPRA regulations and policies.</i>

15.	35.1	Otherwise state [<i>insert the responsible person for security of the site</i>]
B. Time Control		
16.	36.1	The Contractor Shall Submit a Programme for the Works within [3 days] of delivery of the Letter of Acceptance.
17.	36.2	The period between Programme updates is [7] days.
18.	36.2	The amount to be withheld by the Project Manager in the case the contractor does not submit an updated programme is: [TZS. 200,000].
C. Quality Control		
19.	44.1	The Defects Liability Period is 180 days .
D. Cost Control		
20	52.7	Minimum Amount of Interim Payment Certificate will be 15% of the contract sum
21	54.1	The currency of payment shall be Tanzania Shillings
22.	57	The contract is not Subject to price adjustment.
23.	58.1	The amount of retention is [10%] of value of works of
		Interim Payment Certificate’.
		Limit of retention will be [5%] of contract price.
24.	59.1	The amount of liquidated damages is 0.1% of Contract Price per day . The maximum amount of liquidated damages must be equivalent to the amount of the performance security.
25.	60.1	The bonus for early completion: [N/A].
26.	61.1	The amount of advance payment: N/A
27.	62.1	The Performance Security shall be: 10% of the Contract price .

28	66.1	Contractor shall handover the site and the works to the Employer within seven (7) days after the project manager issuing the Certificate of final completion (after end of the defect liability period)
		E. Discharge of the Contract
29.	68.1	As built drawings shall be supplied by the contractor by (14) days after issuing of Substantial Completion certificate. Operating manual shall be supplied by the contractor.
30.	68.2	The amount to be withheld by the Project Manager in the case the contractor does not submit operating manual is: 5% of the contract price.
31.	69.2 (i)	Number of days for which the maximum amount of liquidated damages can be paid is 30 days.
32.	70.1	The percentage to apply to the value of the work not completed, representing the Employer's additional cost for completing the Works, is fifteen percent (15%).

SECTION VI: SPECIFICATIONS

1.0 EXCAVATION AND EARTHWORK

1.1 Nature of excavation

The contractor must ascertain for him the nature of the material to be excavated and price work accordingly as no allowance will be made beyond the contract sum of any alleged ignorance in this respect.

1.2 Excavations generally

Excavations have been measured from the drawings including the Engineer's site plan showing existing contours. It is the responsibility of the contractor to check the commencing levels prior to commencing the work as no extra payment will be made in respect of any alleged excavations carried out due to the commencing levels being above that shown upon the drawings without the prior written agreement of the structural Engineer prior to commencement of excavation.

1.3 Site clearance

The contractor shall clear the construction areas within the site of all bushes, roots, boulders, natural obstruction, rubbish and any other or artificial obstructions, which would interfere with construction of buildings, roads, paths and drains.

1.4 Over- site excavation

Excavated material suitable for back-filling around foundations and for making up levels under roads, floors etc., is to be kept separate from soil spoil heaps and to be re-used as directed or spread and levelled on the site at the end of excavation operations when found to be surplus. The Quantity Surveyor will measure the amount of any such disposal on site. Vegetable soil is not to be used for back filling around foundations.

1.5 Excavation below required depths

Should any excavation be made below the levels or line shown on the drawings or otherwise required by the Structural Engineer, the contractor must fill up the resultant over- excavation to the proper levels or lines with concrete nominal mix (1:4:8) at his own expense (see "concrete work")

1.6 Filling

The fill shall be clean, selected coarse sand or gravel. It should be taken from borrow pits if the soil on the site is found to contain too much fines and too low plasticity limit to be used as fill.

The fill shall be deposited in horizontal layers of max.200mm thick. As soon as possible after the fill is laid out, it should be compacted in min, three passes

of a vibratory- roller and /or vibrating-plate compactor. The equipment to be used must be approved by the Engineer.

At each area (control area) of 500mm²-compacted fill, three field density tests (eng.by the sand- replacement method) should be taken randomly

The control area to be accepted if all three test results are above 97% of the max. density as determined at a homogenous mixing of all three samples by the Standard Proctor Method. Otherwise, repeat the test, each time with three new samples until the above requirement is met or re-compact and test again.

1.7 Return, fill in and ram

Return, fill in and ram suitable filling material as described above around foundations and other concrete structure in layers not exceeding 150mm thick and carefully ram and consolidate with power rammer. No filling in shall be executed until concrete foundation etc....have been inspected and approved by the Structural Engineer.

Regardless of the means of back filling and compaction adopted, the contractor is responsible not only for the standard of the work but also for any possible damage of the permanent work or adjustment structure.

1.8 Levelling

No item is measured for levelling and consolidating ground and rates for excavation must include for levelling and preparing the ground for concrete or other works including ramming or rolling.

1.9 Soil sterilization

Anti-termite treatment is to be carried out by an approved specialist firm who will be required, upon completion of the soil sterilization, to furnish a written guarantee qualifying the following: -

- That the chemicals applied comply with the requirements specified herein for chemical concentration and rates of application.
- That the treatment will remain effective against termite infection for a period of five years.
- The free re-treatment by the firm of any areas showing signs of infestation before the expiry of the five-year period.

The chemicals used shall be one of the following: -

- i. Aldrin 0.5% applied in oil solution or water emulsion.
- ii. Benzene hexachloride,0.8% of gamma isomer applied in oil solution or water emulsion.
- iii. Chlordane 1.0% applied in solution or water emulsion. iv. Dieldrin 0.5% applied in oil solution or water emulsion.
- v. Lindane;0.8% in oil solution or water emulsion.

- vi. Pentachlorophenol;5% in oil solution
- vii. Trichlorobenzene; 1 part to 3 parts oil.

Some of the chemicals listed above are toxic to animal and plant life and must therefore, be applied only with caution by an experienced person. Where individual water supply systems are proposed precautions must be taken to prevent in littering and endangering the water supply. Treatment shall not be made when soils of fill are excessively wet or immediately after heavy rain.

Precautions must be taken to prevent disturbance of the treatment by animals or human contact with the treated soil. The treated area is to be covered as quickly as possible after treatment. The rate of application is to be 5 liters per square meter and the areas measured include those under floor and round wall and column foundation.

The contractor shall notify the structural engineer in sufficient time before the filling of foundation trenches and laying of concrete floor bed in order that the Architect may nominate a specialist firm to execute the soil sterilizations.

Any additional cost caused by the contractor not rendering sufficient prior notice to the Architect will be borne entirely by the Contractor.

1.10 Disposal of surplus excavated material

Surplus excavated material will be carted away from the vicinity of the walls and deposited, spread and levelled on areas to be allocated by the Structural Engineer, reasonably adjacent to the site.

1.11 Disposals of water

The contractor shall keep the excavation free from standing water and silt (or excavated material softened by water) and he shall include for the cost of pumping, construction of temporary drains; soak-way pits, etc.; as deemed necessary to achieve this. An item has been included for this in the bill in each relevancy section. A provisional sum has covered the cost of pumping to dispose of any spring or running water. If spring or running water is encountered the cost of any pumping ordered by the structural Engineer will be paid for in accordance with the Dayworks schedule.

1.12 Planking and strutting

Side of all excavations must be supported in order to prevent falls from or collapse of the earth face. The "Planking and Struttin" is deemed to include any method or methods, which the contactor elects to adopt to uphold, protect and maintain the sides of excavation. The contractor will be responsible for any consequences of this failure in this respect including clearing away fallen materials and any extra concrete or other works including formwork ordered by the Structural Engineer due to such failure. An item has been included in these Bills in each relevant section.

1.13 Hardcore

Hardcore shall be hard crushed stone to pass a 100mm ring in all directions. No sand, quarry dust or fine material will be permitted. All hardcore beds shall be topped with a layer of fine stone or aggregates minimum size 12mm to fill the voids on the surface to receive concrete beds. Rates for hardcore shall include for levelling or finishing or laying to falls and consolidating by rolling as described for "Filling" above.

2.0 CONCRETE WORK 2.1 Materials and workmanship generally

The recommendation of the recent British Standard Codes of Practice BS 8110 for the Structural use of reinforced concrete in building shall be deemed to be incorporated in these preamble clauses unless otherwise specifically stated.

2.2 Material generally.

All materials to be used in the work shall conform as to quality and description as specified hereunder and shall be equal to approved samples. In particular no materials shall be used until approved sample shall be supplied to the Consulting Engineer for approval at least one week before ordering in bulk and delivery to the site. Any material delivered to the site, which has not been previously approved by the Structural Engineer shall be the Contractor's liability. All materials shall be transported, handled and stored on site so as to preclude damage deterioration or contamination. All condemned materials are to be removed from the site within 24 hours.

2.3 Cement

The cement, unless otherwise specified on the drawings shall be Ordinary Portland Cement of approved manufacture, delivered in the manufacturer's bags and shall comply in all respects with the requirements of the latest British Standard 12. The consignments of cement shall be delivered in sealed bags and shall be stored on the site so as to be used in the order in which they are delivered. The structural engineer shall have the right to take samples for testing in accordance with BS 12 and the contractor are to obtain current certificates of test from the manufacturer prior to bulk deliveries. Under no circumstances is High Alumina Cement to be used.

Rapid hardening cement may be used in lieu of ordinary Portland cement only with prior approval of the architect or Engineer, provided that all conditions applying to its use are strictly observed. Any additional expenses in connection with the use of such cement shall be borne by the Contractor.

2.4 Aggregate generally

All aggregate shall be from approved reputable source and shall be strong, hard, durable or limited porosity, free from dust, soft materials, earth or other extraneous matter, and washed and/ or screened by the contract if so, required by the Structural Engineer. Sample shall be provided as often as called upon by the Structural Engineer for testing in accordance with BS 882. Normal aggregated will have particle densities of greater than 2000kg/m³ but not exceeding 3,000kg/m³ only approved materials shall be used.

Graded samples of all types of aggregate shall, after approval, be kept on site behind glass for visual checking of subsequent deliveries for grading, shape and where applicable, color. Aggregate shall be store on site on paved areas with divisions between each type of aggregate, and shall be used in the order in which they are received on site No aggregate shall be stored directly on the ground.

2.5 Fine Aggregate

The contractor shall ensure that the grading of fine aggregate shall be such that not more than 10% by weight shall exceed 5mm in size and not more that 10% by weight shall pass a sieve BS. No.100. between these limits the grading shall conform to the grading for either zone 1,2 or 3 (BS.882).

2.6 Coarse aggregate

Coarse aggregate shall be clean, well-graded crushed granite stone or other equal and approved stone from an approved quarry and washed if required by the Structural Engineer. The pieces shall be regular or rounded in shape and shall have granular or crystalline or smooth (but not glassy) non- powdery surface. Flakey and laminated pieces, mica and shale shall only be present in such quantities as not to affect adversely the strength and durability of the concrete.

The four nominal aggregate sizes shall be 40mm (1 ½"), 20mm (¾"), 10mm (3/8"), 6mm (¼"); and the grading when analyzed as described in BS.812 shall be within the limits given in BS.882. Structural Engineer will specify sizes of aggregates to be used in specific areas. For most work 20mm maximum size aggregates will be used. The nominal maximum size of coarse aggregate should be no greater than ¼ of the minimum thickness of concrete section or element.

2.7 Water

Water used for mixing of concrete, washing out of shuttering and similar purpose shall be clean, fresh and free from organic impurities in amounts likely to impair the quality of the concrete and should comply with requirement of BS 5328 bad BS 3148: 1980 "Methods of test for water making concrete."

2.8 Admixtures

Structural Engineer will approve all concrete admixtures after submission of specifications or proprietary brands and relevant trial mix verification at site by Contractor. Admixture to comply 5075; Concrete Admixtures.

2.9 Steel reinforcement

Steel for reinforced concrete shall comply with the following specification:

-
- i. Mild steel rod reinforce shall comply with BS.4449
- ii. High tensile steel reinforcement shall be either cold worked deformed high tensile bars having a guaranteed minimum yield stress of 460 N/mm² and other physical qualities in accordance with BS.4449.
- iii. Welded steel fabric reinforcement shall comply with BS.4483.
- iv. BS.8110, the structural use reinforced concrete in buildings.

An approved manufacturer shall supply all steel reinforcement; and the contractor may be required to obtain a manufacturer's test certificate in respect of steel reinforcement supplied. In the absence of such a test certificate, the contractor may be required to submit samples to be tested at the contractor's expense in such manner as to comply with BS8110 requirements.

The steel shall be stored so that it is kept clean and reasonably free from rust. The placing of all reinforcement shall be checked by the Engineer and in no circumstances is concrete to be deposited around any steel that has not been passed. At least twenty-four hours' notice shall be given to the Engineer that reinforcement will be ready for inspection.

2.10 Bending and fixing of reinforcement

All bending, cutting and fixing to be in compliance with the British Standard code of Practice, BS 8110 and BS.4466 Bending schedules are incorporated in the contract drawings.

The number, size, form and position of all reinforcement shall unless otherwise directed or permitted by the Architect, be strictly in accordance with the drawings. Bars shall be of the required lengths, and lapping, except where indicated on the drawings, is not permitted unless approved by the Engineer. Overall dimensions shall not be exceeded and shall not be less than 6mm below the required dimensions. The sizes of links and the like shall be within tolerance of 3mm under or over the specified dimensions. Any tolerance in the top length of the bar as cut shall be taken up in the end hooks or other approved portions of the bar. The internal radius of the bends at corners of links and the like shall equal half the diameter of the bar embraced by the link. Laps in bars of random lengths shall be staggered in such a way that no more than 1/3 of bars having same number are to be lapped in the same section. The steel reinforcement shall be assembled and fixed in the form of a rigid

cage. To prevent displacement before or during concreting the bars shall be securing to each other with approved wire. Concrete distance blocks shall, unless otherwise directed, be used between the reinforcement and the bottom and sides of the forms to ensure correct concrete cover to the bars, as specified on the drawings. The specified cover shall be provided and maintained within the specified tolerance.

The minimum clear distance between adjacent bars shall be 25mm horizontally and 25mm vertically, Spacer bars shall be inserted at such intervals that the bars do not perceptibly sag.

Great care must be taken to ensure the correct positioning of beam and column starter bars and to secure projection bars against displacement both during and after concreting.

At the time of fixing and when and when concrete is being placed, all reinforcement shall be free from oil, paint, grease excessive dust and scale or any other coating, which would destroy its bond with the concrete. **2.11 Formwork to produce a fair face board finish (wrought formwork).**

Formwork described as wrought shall be constructed of or lined with 100mm wide planed well cramped together or plywood to leave a fair smooth finish in the exposed concrete face the shuttering is removed.

2.12 Construction and Movement joints

The positioning, type and frequency of construction joints are to conform to requirement of BS 8110 and be approved by Engineer. Methods of forming movement joints to follow drawings and the requirements of BS 8110.

2.13 Concrete grades

Only designed concrete mixes complying with BS 5328 shall be used. Concrete must comply with the requirements set out in the following table according to the grade (This is for guidance only)

GRADE	NOMAL MIX	MAX.SIZE OF COARSE AGGREGATE	MAX WATER CEMENT RATIO BY WEIGHT	MINIMUM CRUSHING STRENGHT OF WORKS TEST CUBES(N/mm2)	
				7DAYS	8DAYS
30	1:1:2	2mm	0.50	20	30
25	1:1 ½:3	20mm	0.55	17	25.5
20	1:2:4	20mm	0.60	14	20
15	1:3:6	20mm	0.60	8	14
10	1:4:8	40mm	0.60	-	10

2.14 Concrete Production, Supervision and Tests

Concrete should be produced in accordance with BS 5328 which requires tests to be made on constituent material in accordance with relevant British Standard and control test be made on concrete to ensure compliance with

specified requirement. Engineer will in addition approve procedures for placing, compacting, curing and working in hot weather.

Concrete should meet appropriate requirements specified in BS 5328 for

- a) Characteristics compressive strength
- b) Specified mix proportions
- c) Maximum and minimum cement content
- d) Maximum free water/cement ratio
- e) Workability
- f) Air content of concrete
- g) Temperature of fresh concrete
- h) Density of fully compacted concrete.

2.15 Preliminary cube tests

The contractor shall specify the sources from which the aggregate will be obtained and shall deliver at his own cost sufficient materials to enable preliminary cube tests to be carried out and approved by the Engineer. The Contractor will be responsible for submitting his proposals for the concrete mix proportions together with aggregate grading curves to the Architect for approval and for the payment of the fees of an approved Testing Authority in carrying out the crushing tests. The strength of the preliminary cubes must be a minimum of 33% above in the above table, which is the minimum works strength.

The approval of any mix by the Engineer will not relieve the contractor of the responsibility for ensuring that all concrete used in the works obtain the minimum works strength shown above.

In proportioning the concrete, the quality of cement shall be determined by weight and the quantities of fine and coarse aggregate by either volume or weight, due allowance being made for the moisture content of the aggregate.

Only sufficient water shall be added to the cement and aggregate during mixing to produce a concrete having sufficient workability to enable it to be well consolidated, to be worked into the corners of the shuttering and around the reinforcement, to give the specified surface finish and to have the specified strength. When a suitable amount of water has been determined the resulting consistency shall be maintained throughout the corresponding parts of the work and the slump test or compaction factory test shall be carried out from time to time to ensure the maintenance of this consistency. In no case should the slump be more than 65mm as determined by the standard slump test nor should the compaction factor be more than 0.87 as determined by the standard compaction factor test as described in BS 1881.

Should the Contractor wish to use patent, plasticizing compounds or other admixes, and those shall be approved by the Engineer and be used in accordance with the manufacturer's publications.

2.16 Work cube tests

Work cube tests shall be made throughout the contract. Each cube shall be inscribed with the date of manufacture and identification mark. A record shall be kept for each batch of cube showing the position in the works which the concrete represents, the date of manufacture, the mixture and slump of the concrete, particulars of the cement and aggregate used, a statement of whether or not the cube were vibrated and other information related to the subsequent history of the cubes.

The cube shall be made, cured and tested in accordance with the requirements BS.1881 when directed by the Engineer and in his presence or that of the Approved Test Authority. A sample of concrete shall be taken at random on eight separate occasions during each of the first 5 days of using that mix.

Thereafter at least one sample shall be taken on each day any concrete of that particular mix is used. From each sample four cubes shall be made two for testing at 7days and two for testing at 28days. The work cube result shall be examined both individually and in consecutive (but not overlapping) sets of four, for which the average and the range of each set are calculated.

The mix proportions shall be modified to increase the strength if, in the first and consecutive (but not overlapping) sets, any of the following conditions are not satisfied: -

- i) Not more than 2 individual results of the 40-cube test should fall below the specified work cube strength,
- ii) No value of the range in any set should exceed 4 times the designed standard deviation.
- iii) Not more than one set should have an average, which is less than the specified strength plus $1.1/3$ times the designed standard deviations.
- iv) No value of the average for any set should be less than the specified strength plus designed standard deviation.

After 10 consecutive sets of results have been obtained the overall average and the standard deviation of the 40 results shall be calculated and any appropriate modifications made. Subsequently, if any of the foregoing conditions are not satisfied, the overall average and the standard deviation of the previous consecutive 40 results, including the non-complying sets, should be calculated and the appropriate steps taken if the overall average

strength twice the standard deviation is less than the specifies work cube strength.

2.17 Quality control requirements

2.17.1 Supervision

A competent person shall be employed whose duty shall be to supervise all stages in the preparation and placing of the concrete. He shall supervise all tests on the materials and cubes and the maintenance and calibration of mixing and measuring plant. This person shall also be responsible for keeping and accurate record of the dates on which concrete is poured and where. Where the Engineer is not satisfied with the performance of concrete supervisor he shall recommend to the Architect for removal from site.

2.17.2 Batching and mixing plant

The quantities of cement and of fine and coarse aggregate shall be determined by weight. The amount of water added shall be measured, allowance being made for the water content of the aggregate. The accuracy of weighing and measuring equipment shall be 2 ½%. Measuring equipment for water shall be maintained in a clean serviceable condition.

2.18 Workmanship

2.18.1 Placing of reinforcement

Reinforcement shall be accurately placed and maintained in the position described on the drawings or elsewhere to the entire satisfaction of the Engineer. Bars intended to be in contact at passing point shall be securely wired together with 16 gauge annealed soft iron tying wire.

Binders and the like shall tightly embrace the bars and any slackness or misplacement of bars shall be rectified before the Engineer is called for inspection. Spacers of approved design shall be used for ensuring the correct positioning of the bars and diagonal wiring shall be provided to ensure rigidity of all assembled units of reinforcement. The vertical distance required between successive layers of bars in beams or similar members shall be maintained by the provision of mild steel spacer bars inserted at much intervals that the main bars do not perceptibly sag between spacers. The rates for reinforcement must include for all requisite wiring. Spacers and precast concrete blocks to maintain the required spacing and cover. All bars are to be bent in accordance with BS 4466: 1969.

Cover of concrete to the reinforcement shall be, unless shown otherwise; -

Column	-	40mm minimum to main bars
Base	-	50mm minimum to main bars
Beams	-	25mm minimum to main bars
Slab	-	15mm minimum to main bars
Wall	-	25mm minimum to main bars

Raft slab - 100mm minimum to main bars

Splices to future work shall be covered in a manner approved by the Engineer to prevent rusting and deterioration. Before any concreting is carried out the approval of the Engineer as to the correctness of the fixed reinforcement shall be obtained but such approval shall not remove the responsibility for the correctness of the placing from the contractor. During concreting a competent steel fixer shall be in attendance on the concrete gang to make minor adjustments to the position of bars should they become displaced.

2.18.2 Formwork generally

Formwork design and construction should take into account of safety and surface finish required and to conform to requirement of BS 8110 and BS 5975. Dimensional deviations of in-situ concrete shall be to limitations set in BS 5606

All formwork and moulds shall be rigidly constructed to accurate shape and dimensions as described on the drawings and to requirement of BS 5975. Timber shall be well seasoned, free from loose knots and be of a kind thickness that will avoid deflection and warping, remaining true to line and level. Faces in contact with the concrete shall be free from adhering grout, projecting nails, splits or other defects and shall be coated with an approved mould oil so as to prevent grout adhering to them, care being taken to prevent such coatings from any contact with the reinforcement.

Formwork shall be braced and strutted to prevent deformation under the weight and pressure of the wet concrete, construction loads, winds and other forces. The bottoms of beam boxes shall be erected with an upward camber so as to prevent downward deflection. Maximum tolerances, which will be permitted in the finished concrete work, are to BS 5606 as follows: -

Dimensions less than 3m	+3mm
Dimensions between 3m & 15m	+6mm
Dimensions over 15m	+10mm

Joints in the moulds of framework shall be carefully made so as to prevent leakage of cement grout and particular care shall be exercised to this respect for moulds in which it is intended to place vibrated concrete. Openings in the formwork for inspection of the inside and for the escape of water used for washing out accumulated debris shall be formed in such a manner that they can effectively be closed before placing the concrete.

Formwork connection and joints shall be constructed so as to permit easy removal of the formwork, but shall be so secured as to retain correct shape under pressure exerted by the wet concrete during placing, vibration, setting

and hardening. If any wire ties passing through the concrete or bolts are used, measures shall be taken to prevent rust, strains on the finished work and any holes left by the removal of such ties shall be made good. Formwork shall be provided for top faces of sloping work and anchored to prevent floatation, but this shall apply only where the slope exceeds 15 degrees. The formwork for beams and slabs shall be erected bottoms. Props for an upper store shall be placed directly over these in the storey immediately below and the lowest prop shall bear upon work sufficiently strong to carry this load.

If formwork of columns; walls and other deep sections is erected to full heights, one side shall be left open and shall be built up in sections as placing of the concrete proceeds. Before concreting, bolts and fixings shall be in position. Cores and other deices used for the forming of openings, holes, pockets, chases, recesses and other cavities shall be fixed to the formwork and no subsequent holes shall be cut in any concrete without the Architect's approval.

2.18.3 Mixing of Concrete

All concrete shall be mixed in batch mixing machines. Hand mixing shall not be permitted. All mixing machine shall be of the fixed drum types and not smaller in size than 0.40/0.28 CM drum mixers will not be permitted. The mixer shall be of the type equipped with an accurate measuring device designed so that no unauthorized person can tamper with the valve or vary the quantity of water delivered once this has been approved and set. The mixing procedure to be adopted by the Contractor shall be approved by the Architect.

The Architect shall approve mixing of each batch. Mixing of each batch shall continue until the concrete is uniform in colour and, in any case, for not less than two minutes after all the materials and the after is used in the drum. The entire contents of the drum shall be discharged before the materials for the succeeding batch are fed into the drum. Upon completion of the day's mixing, the drum shall be thoroughly cleaned free of adhering concrete.

2.18.4 Distribution of Concrete

The concrete shall be distributed from the mixer to the position required by approved means. Which do not cause separations or otherwise impair the quality of the concrete. All equipment shall be cleaned before commencing mixing and distribution and be kept free from set concrete. All concrete must be in position and consolidated before the initial set is commenced and the contractor shall ascertain the initial setting time for the brand of cement being used and ensure that his means of distribution are such that it is impossible for concrete to have set prior to placing.

Distribution by means of mortar pane generally will be permitted, but for important large structures such as slabs, large beds and elsewhere instructed by the Engineer the minimum requirements shall be wheelbarrows, ramps and runaways over the reinforcement

2.18.5 Placing of Concrete

Before placing of concrete commences, the formwork shall be examined and any accumulated water and rubbish lying therein shall be removed. The concrete shall be placed as near to its permanent position as is practicable and shall not be worked along the formwork to that position. It shall not be dropped from a height not handled in a manner likely to cause separation of the aggregate or loss of the cement matrix. In columns and other similar members, the bottom shall be first filled to a depth of between 150mm and 200mm with a cement mortar consisting of sand, cement and water with the sand and cement in the same proportion as that specified for the general mix in that member. The mortar shall have a consistency such that it will work up the framework and fill in spaces, which may occur due to close spacing of reinforcement in the splice.

This mortar must be placed immediately in advance of the concrete and shall not be allowed to attain its initial set before placing the main concrete for the member. Each layer of concrete, while being placed, shall be consolidated by the approved methods of ramming/tamping or mechanical vibration so as to form a dense homogeneous material free from honeycombing water and air holes or other blemishes. Concrete shall be placed continuously until completion of the part of the work between the specified construction joints. Approved working joints shall be made wherever stopping of concrete placing occurs. In general, concrete shall be placed in a single operation to the full thickness and depth of slabs, beams and similar members and in any case, shall be placed in horizontal layers not exceeding 75mm deep in walls columns and other similar members: -

2.18.6 Vibration.

Mechanical vibrators or hand tamping must be used in placing all reinforced concrete work unless the Engineer has approved specially designed mixes and preliminary work cube test results have been obtained without their use. Rates for all reinforced concrete work include for this.

Where mechanical vibration is required the contractor shall allow for using two vibrations at any one time.

2.18.7 Working joints

Working joints shall be of an approved shape and placed at right angles to the axis of the member. The contractor shall submit his proposals for the design and position of all joints on a drawing to the Architect for his approval well before construction is commenced. The position of day to day working joints may be determined so as to meet the requirements of the contractor's concreting programme.

Wherever new concrete is to be placed against concrete that has hardened, the face of the old concrete shall be out back not less than 20mm and all loose particles removed. The face shall than be wire brushed and thoroughly cleaned with water and then coated with a neat cement grout immediately before placing the concrete shall be well rammed and compacted against the prepared face before the neat cement grout sets.

2.18.8 Protection of Concrete

Newly placed concrete shall be protected by approved means from rains, such and dry winds, and exposed faces shall be kept moist with polythene or hessian coverings or other approved means for at least 7 days. Under no circumstances shall concrete be worked upon until it has reached a cube strength of 140kg per square centimeter. Immature concrete shall be protected from damage by falling debris excessive loading vibrations, running or standing water, abrasives or other influences likely to impair the quality or strength of the finished work.

2.18.9 Concrete in Excavation

The length and widths of the excavation shall be as necessary for the proper construction of work below ground and in accordance with the Preamble contained in the section 'Excavation and Earthwork' Blinding concrete has been measured for the net width required for concrete structure and foundations below ground level. Blinding has not been measured to the extra width, if any required for working space. The Architect shall decide the depths where these are not given on the drawings. Any obstructions or unusual solids encountered during the excavation shall be reported to the Architect and dealt with as then instructed.

2.18.10 Removal of formwork

The period elapsing between placing the concrete and removing the framework shall be sufficient to allow the concrete to mature to the extent of being able to maintain its own weight and any constructional and structural loads imposed without damage. The Architect approval for the removal of the formwork shall be as tabulated below:

Position of Formwork	
----------------------	--

Vertical side of wall, columns, beams etc.	2 days
Soffits of beams & slabs (props left)	7 days
Slab and props	14 days
Bottom boards of piles (intermediate support)	12 days
Soffits of beams under 6m span	16 days
Additional: Period for each 0.6m span in excess	1 day

The formwork shall be removed in all cases by gradual easing without jarring and the process shall be such that the sharp edges of the concrete are not chipped and spilled away. If the imposition of a load is anticipated, props shall be provided in an approved manner after removal of the formwork and before the imposition of the loads.

2.18.11 Surface Finishes

Upon removal of the formwork any honeycombing or damaged surface or other imperfections shall be reported to the Architect. No surfaces shall be repaired or otherwise treated until an inspection has been carried out by the Architect and his instructions or approval to remedial work (if any) have been given or obtained.

Concrete surfaces, which are to be plastered, are to be hacked or roughened by an approved means to form a key, sawn formwork is measured for all surfaces requiring support and subsequently concealed or plastered.

2.19 Precast Concrete

Where precast concrete members are specified, these shall be constructed in molds of approved design and samples from the molds shall be approved before quality production of the member is commenced to requirement of BS 8110/ Large precast members shall be lifted only at points, which will not damage the member, and if necessary temporary bracing of timber shall be used to case the member until it is in position. Small lintels and other small members may be cast in-situ at no extra cost at the contractor's option. Allowance must in all cases be made for any extra reinforcement to contract temporary stresses whilst handling, transporting and hoisting precast concrete members. Molds for precast units described as finished fair on exposed surfaces shall be lined with plywood or hardboard to leave a fair finish on the exposed concrete face when the mold is removed.

The concrete shall be of the grade specified on the drawings but with maximum aggregate size 12mm and shall be thoroughly vibrated in the molds and shall not be removed until seven days after placing the concrete.

Care must be taken that no concrete is allowed to become prematurely dry fresh concrete must be carefully protected from the rain, sun and wind by means of 'Sisal-Kraft' paper, well-wetted sacking, wet sand or other approved means. This protective layer and the concrete itself must be kept continuously wet for at least seven days after the concrete has been placed.

Prices for precast concrete shall include for all molds, reinforcement as specified, hoisting and fixing in the position required. Bending and pointing as described and temporary props and other necessary supports.

2.20 Sub-contractors work Incorporated in the Structure

It shall be the contractor's responsibility to co-ordinate sub-contractors and others for incorporating any electrical conduit, plumbing fixtures and pipes, bolt hole, etc., in the concrete members as required and shown on the drawings. The contractor shall submit details of cable and pipe runs to the Architect before the work is put in hand and shall have the Architect's approval of the layout. No holes or chases shall be cut on concrete without the approval of the Architect.

2.21 General

No holes or chases are to be cut in any part of the reinforced concrete construction without first consulting the Architect. No part of the reinforcement shall be used for conducting electrical current. Notice must be taken of any appearing on the drawing and not mentioned in these preambles.

2.22 Movements and Separation Joints

Movement joints shall comprise of Bitumen impregnated softboard or similar approved. Joints topping are to be 'plastic' or similar approved hot poured rubber bitumen compound.

Pointing to vertical joints is to be 'plastic joint' or similar approved bituminous putty applies with a gun. Joints are to be at least 12mm deep and the gap is to be formed either by raking cut (in the case of expanded polystyrene) or by temporary wooden battens of the required width and 12mm deep.

Rates for the expansion or separating joint shall include all necessary labor and the materials described above., temporary supports and cutting where required to line with concrete surface finished to falls. Formwork has been measured as a separate item to one side only of expansion joints.

2.23 Mortise and Pockets

Mortise or pockets for holding down bolts or dowels shall be formed in concrete to the size and shapes shown on the drawings. Mortises shall be formed by the use of expanded polystyrene block of the required shapes and sizes carefully and accurately placed and maintained in position whilst the concrete is poured.

Rates for mortises shall include for all necessary templates and raking out and the complete removal of the polystyrene when the concrete has set. N deduction from concrete quantities has been made for any mortise, pocket or any other void in the concrete of 0.05 cubic meters or less and the Contractor may take this into account when pricing. Grouting up has been measured separately.

3.0 WALLING 3.1 Water

Water shall be as previously specified in 'concrete work'

3.2 Cement

Cement shall be as previously specified in 'concrete work'

3.3 Fine Aggregate

Fine aggregate shall be as previously specified in 'concrete work'

3.4 Coarse Aggregate

Coarse aggregate shall be as previously specified in 'concrete work' and shall comprise aggregate of 6,10 and 20mm gradings in equal proportions.

3.5 Lime

Hydrate limes for cement/lime mortars shall comply with BS 890 semihydraulic class 'B' calcium limes.

3.6 Bricks and Clay blocks

Clay bricks and blocks, solid and hollow, shall comply with BS 3921: The manufacturer and /or supplier of clay bricks and clay blocks shall be approved by the Architect.

The vertical joints of one course should not be less than a quarter-brick from the vertical joints of the courses above and below. Where strength is critical, bricks with one frog only should be laid with the frog upwards so that it is automatically flushed with mortar.

3.7 Joints

The joints of brickwork may be finished by one of the following methods.

- i) With a flush joint as the work proceeds this joint being formed of the actual mortar used in bedding the bricks

- ii) Struck or recessed joint formed in the mortar as the work proceeds when it has gone some way towards setting. Recessed pointing must be even and not varying in depth where not recommended otherwise the recess shall be 6mm deep.
- iii) Joints raked out while mortar is soft and cleaned down and pointed at completion. When the joints are raked out and pointed later the pointing mortar should be of a composition similar to that of the bedding mortar.
- iv) Joints raked out and left as key for plaster or roughcast.

3.8 Concrete Blocks

Solid and hollow concrete blocks for walls comply with BS 2028 type 'A' except that the recommended mix shall be 1:3:6 cement; fine and coarse aggregate respectively by volume and are to have sharp arises. Blocks are to be manufactured on site in approved block making machines and shall be solid or two cavity hollow types as specified on the drawings. No damaged blocks shall be used in walling and half or other part blocks required to maintain bond shall be cut true and even.

The concrete is to be placed into the moulds in thin layers and shall be properly tamped or vibrated to secure complete consolidation without voids or flaws produce smooth surface and sharp straight corners.

Blocks shall be cast on loose pellets and after removal from the moulds shall be carefully stored under for at least 24 hours before the pellets are removed. The blocks shall thereafter be stored under cover for a further seven days protected from the sun and drying of the blocks may commence on the ninth day after manufacture and no blocks may be used within 14 days of their production.

The compressive strength of the type 'A' concrete blocks shall be not less than: -

- o Average of 13 blocks 50kg per square centimeter (700lbs.per square inch)
- o Lowest individual blocks 40kg.per square centimeter (580 IBS per square inch)

Concrete louvre blocks shall be of an approved type and manufacture. The shall be with inclined faces and have overall size 450 x 150 x 150mm (excluding lip protruding outside he bedding face).

3.9 Fair face work

Walls described as finished with fair face shall be constructed with blocks selected for their uniformity of size with a smooth exposed face with no chips, blemished, pinholes or cracks. Walling shall be pointed with a neat

flush joint as work proceeds and on completion shall be brushed down and left thoroughly clean.

3.10 Mortar

The mortar used for walling shall be composed of one part of cement two parts of hydrated lime to nine parts of sands (1:2:9) measured in gauge boxes and thoroughly mixed dry and preferably with an approved mixing platform with water added afterwards until all parts are completely incorporated and brought to a proper consistency and used within the hour. No partially or wholly set mortar will be allowed to be re used or mixed.

3.11 Workmanship

All blocks and stone to be wetted before laying out the top of walling where left off, shall be wetted before recommencing building, walls to be kept wet three days after building.

All walling to be built true plumb and level with all perpend vertical and in line and work shall not rise more than 900mm above the adjoining work and all such risings are to be properly raked back.

3.12 Damp proof course

Damp proof course between foundations walls and the oversite concrete slab shall be hessian based bitumen strip to BS 743 type 5A the same width as block walls. The damp proof course shall be bedded in cement mortar (1:4) with 150mm-end laps and full width at passing and angles. Damp proof courses are required on all external and internal foundation walls.

4.0 ROOFING

4.1 Vermiculite lightweight screed

Vermiculite lightweight screed shall be mixed in proportions of 6 parts by volume of vermiculite Grade 5 to 1 part of Ordinary Portland Cement with approximately 2 parts of clean potable water to give a density of 700 kg per m³.

Vermiculite screed is to be finished to receive a topping coat of water proofed cement and sand (1:4).

4.2 Roof waterproofing

The waterproofing shall be carried out with cement and sand (1:4) waterproofed with 'Puddle' or other equal and approved waterproofing compound in strict accordance with the manufacturer's printed instructions.

4.3 Bitumen felt roofing

4.3.1 Generally

A specialist subcontractor to be approved by the Architect shall execute bitumen felt roofing.

4.3.2 Materials

Bitumen felt roofing (or built up roofing) shall be in accordance with BS 747 (roofing felts). The roofing shall be composed of three layers of single roofing felt of specified quality; weight and make.

4.3.3. Fixing

Bitumen felt roofing shall be carried in accordance with the requirements of Cp 144 part 1:1968, (built up bitumen felt). The roof screed must be laid to falls of not less than 1 degree from horizontal and the screed must be thoroughly dried before laying of bituminous is commenced.

The first layer shall be partially bonded to the roof deck with bitumen to allow sufficient easing of vapor pressure. The second layer shall be fully bonded to the first layer with minimum 150mm laps at ends and edges in bitumen. The top layer shall be similarly bonded to the second layer.

4.4 Aluminum roofing

4.4.1 Materials

Aluminum roofing shall be corrugated aluminum roof sheeting manufactured by ALUCO or other approved manufacturer, and shall conform to the requirements of BS 2855 or 3455. The gauge and the surface finish of the sheets shall be as recommended by the manufacturer, in writing, and approved by the Architect. All accessories shall be of aluminum alloy.

Whenever trough sheets and heavy trough sheets are used they shall comply with the requirements of BS 3428 type 'A' for trough sheets and type 'B' for heavy trough sheets.

4.4.2 Fixing

The sheets shall be fixed to steel angle or timber purlins with aluminum alloy bolts and nuts. The bolts shall be at least 50mm longer in the shank than the purlin to which they are fixed. All bolts shall have approved washers.

Fixing of the sheet must conform strictly to the printed instructions or otherwise to the requirements of CP 143 part 1 BS 2855.

4.5 Galvanized sheet roofing

4.5.1 Materials

Galvanized sheet roofing shall be corrugated iron as manufactured by GALCO and shall comply with BS 3083:1959: Hot dipped galvanized corrugated steels for general purposes. In addition to the manufacturer's recommendation, the gauge and the surface finish of the steels shall be specified and approved by the Architect. Accessories that shall comply with BS 1091:1963 "Pressed steel gutters, rainwater pipes, fittings and accessories"

4.5.2 Fixing

The sheets shall be fixed to steel angle or timber purlins with roofing nails, bolts and nuts or any other accessory to be approved by the Architect.

Fixing of the sheet must conform strictly to the printed instructions or otherwise to the requirements of CP 143 part 2 BS 2855:1962.

5.0 CARPENTRY 5.1 Timber generally

The timber used for carpentry shall be sound, well-conditioned, properly seasoned to suit the particular use and free from defects or combination of defects rendering it unsuitable for the purpose intended. All timber used structurally shall comply with the relevant requirements of and graded in accordance with the export of Timber Ordinance (cap, 288); The export and Grading of Timber Rules 1969.

All timber is to be ordered as soon as the Contract is signed and is to be delivered to the site for open stacking for as long as possible use. All timber will be inspected by the Architect upon arrival at the site and if not approved by him shall be removed from the site forthwith. Notwithstanding the Architect's approval, any timber incorporated in the Works found to be in any way defective before the expiry of the Defects Liability Period shall be removed and replaced at the sole expense of the Contractor.

Timber shall be free from live borer beetle or other insect attack when brought to the site. The contractor shall be responsible to the end of the Defects Liability Period for executing any work necessary to eradicate insect attack at his own expense including the replacement of timber attacked or suspected of being attacked notwithstanding that the timber may have been inspected already and passed fit for use.

5.2 Moisture content

All timber shall be seasoned to moisture content; if not otherwise specified of not more than 15%. The Contractor must allow for the costs of any kiln drying which may be necessary to obtain this figure.

5.3 Samples and testing

The Architect shall be entitled to select any samples he may reasonably require of materials or prototype of special construction elements for the purpose of testing. (e.g. for moisture content; identification of species, strength etc).

5.4 Protection

All timber delivered to the site shall be stored under cover clear of the ground and protected from sun and dampness and shall be stored in a satisfactory manner to prevent attack of termite, insects or fungi.

5.5 Softwood

Timber for structural use, including rafters, purlins etc. shall be of Grade II strength and Grade I appearance. The softwood shall be a seasoned crepes, cedar pine or podo-carpus, which shall be pressure impregnated with the full cell process as described below, but the contractor's timber requires pricing attention is drawn to the Day works Schedule where the basic price of various timber requires pricing, in the event of one these timbers being selected as an alternative then these rates will be used in calculating new rates for the item of carpentry concerned.

5.6 Pressure impregnation

The softwood described, as pressure impregnated shall be treated with the "Celcure A' or "Tanolith C" full cell process. Timber must be seasoned to a moisture content not exceeding 25% before being treated. The treatment shall be to the maximum standard of:

- Solution concentration – 2%
- Absorption of preservative -520 liters per cubic meter
- Net dry salt retention -10.4kg per cubic meter

After treatment of timber shall be seasoned to the specified moisture content. Cut ends and faces of timber sawn, drilled and cut after treatment are to be swabbed liberally with approved preservative until saturated, allowed to dry and then treated with a second coat and rates for timber 5 must include for this Approved preservative are: -

Atlas A. Brunophen NR.2, Cuprinol Clear or Water Repellent Clear Enscle Wood treat 55. Hardwood for structural and roof timbers shall be third grade scantlings, strength group E or other suitable and approved durable hardwood.

5.7 Preservative treatment

On delivery to the site all structural hardwood is to be treated with two coats of an approved timber preservative. After fixing the hardwood is to be touched up as required with approved timber preservative.

The Timber preservative shall be coal tar creosote to BS.144 or other equal and approved applied either by brush or by spraying in accordance with the manufacturer's instructions.

Cut ends faces of timber sawn, drilled and cut after treatment are to be swabbed liberally with approved preservatives until saturated, allowed to dry and then treated with a second coat and rates for timber must include for this.

5.8 Nails

Nails shall be galvanized and comply with BS 1202 and screws with BS. 1210. Screws shall be brass unless otherwise described. Bolts, nuts and washes shall comply with Bs.916 and rag-bolts, coach screws and other accessories shall comply with BS. 1494. Washes shall be square minimum 3mm thick and 38mm sides.

5.9 Workmanship

"Unwrot" or sawn timber shall be as left from the saw and shall be the full dimensions stated. All carpentry shall be executed with workmanship of the best quality. Scantling and boarding shall be accurately sawn and shall be of uniform width and thickness throughout. All carpentry work shall be left with sawn faces except where particularly to be wrot.

All carpentry shall be accurately set out in strict accordance with the drawings. All structural timbers shall be framed or jointed together with, as is most appropriate in the circumstances in accordance with the rules of good practice. Joints must be executed in strict conformity with the drawings.

All joints shall be secured with a sufficient number of nails disposed as shown on the drawings and rates must include for the jointing of timbers. Surfaces must be in good contact over the whole area of the joint before securing. Holes for nails must be pre-drilled undersize, holes for bolts must be bored slightly oversize from both sides of the timber and washers must use under the nut which be tightened sufficiently to permanently secure the joint but not to crush the timber.

6.0 JOINERY

6.1 General

The provisions contained in the carpentry section shall apply also in the joinery section where applicable.

6.2 Hardwood

Jointed is to be executed in approved prime, select and locally available hardwood. Hardwood generally will be Mninga (*Pterocapus Angolansis*) but hardwood for fittings and built in furniture may be Mkangazi (African Mahogany-Khaya nyasica) unless specifically described otherwise.

6.3 Workmanship

All timber shall be wrot by machine dressing on exposed faces, with all machine marks sanded out, unless otherwise specified. The dimensions and thickness given in these Bills if Quantities are finished (unless otherwise stated) In the event of nominal sizes being stated, an allowance of 3mm should be allowed for each wrought face.

The joinery shall be worked strictly in accordance with the details drawings and is to be framed up and put together as soon as possible, and is to be stored for as long as possible before wedged up. All joints and angles are to be glued and where necessary cross - tongued with hardwood tongues, and surfaces finished clean and smooth with machine marks sand papered out before fixing.

Should any of the joinery work shrink, wind or fly unduly before the end of the maintenance period of the contract, the work is to be taken down, and new work fixed in its place, together with any other works, which may thereby be affected at the Contractor's sole expense.

Where joinery is described as screwed, this is deemed to include sinking the head of the screws and pelleting with similar timber and grain in with finished joinery. Screws unless otherwise specified, shall be brass. In pricing the items, the contractor will allow for nails and screws and fixing, all labours, cuttings, notching, having, mortising, tenoning and welding except where otherwise provided. Rates are also to include for one coat approved priming paint on all concealed surfaces. Allow in the rates for easing and adjusting all doors and leave in perfect working order.

6.4 Flush door

Flush doors shall consist of hardwood core or framing covered with 6mm plywood both side and complying where applicable with the requirements of BS 459, Part 2

and 2A. Doors described, as skeleton framed shall consist of framing 75mm wide to all stiles, top and bottom rails, with suitable blocks to receive mortise locks on each long edge. Doors described, as solid core shall comprise a solid core of vertical laminations. All flush doors shall be edged all round with 25mm thick hardwood lipping tongued and glued in. Doors described as external shall be covered both sides with 6mm 'exterior' quality plywood as described below.

All flush doors shall be perfectly plain on both faces and free from all waves, pipples or distortions of any kind. Any door, which, after the application of paint or polish shows any defects of this nature, shall be removed and replaced at the Contractor's expense. Sample of flush doors, which the contractor intends to use, must be first submitted to the Architect for his approval.

6.5 Plywood

Plywood shall be manufactured from tropical hardwoods of the first grade with BS 145, and unless otherwise stated shall be 'interior' quality. Where stated to be of 'exterior' quality, the plywood shall be W.B.P bonded weatherproof grade. Where veneered is specified, samples must be submitted to the Architect for his prior approval.

6.6 Blockboard

Blockboard shall be of Tanzania manufacture and comply with BS3444 and shall be of moisture resistant quality.

6.7 Chipboard

Chipboard shall comply with BS.2604 resin -bonded wood chipboard.

6.8 Plugging

All work described as plugged shall be fixed with brass screws to plugs formed by drilling concrete, wall etc. with a screw of suitable "Rawplastic", or other approved plugging compound accordance with the manufacturer's instructions.

6.9 Protection

Any fixed joinery which, in the opinion of the Architect is liable to become damaged in any way shall be cased and protected by the Contractor until the completion of the works and the contractor must allow for this in his rates as no separate item for protection has been measured.

6.10 Ironmongery

All ironmongery will be fixed with matching screws to be supplied by the contractor and the contractor must allow for adjusting locks and striking plates and handling over all keys on completion of the contract with identifying tags attached. The contractor must also allow for oiling locks and higher and leaving them in perfect working order. All ironmongery shall be manufactured by Union, Yale, Dryad and Newman-Tonks Ltd or other equal and approved by the Architect.

SECTION VII: DRAWINGS

WINDOW SCHEDULE		
WINDOW TYPE	HEIGHT x WIDTH	QUANTITY(S)
W1	1500mm x 1500mm	11
W2	1500mm x 1100mm	01
TOTAL		12
DOOR SCHEDULE		
DOOR TYPE	HEIGHT x WIDTH	QUANTITY(S)
D1	2000mm x 900mm	03
TOTAL		03

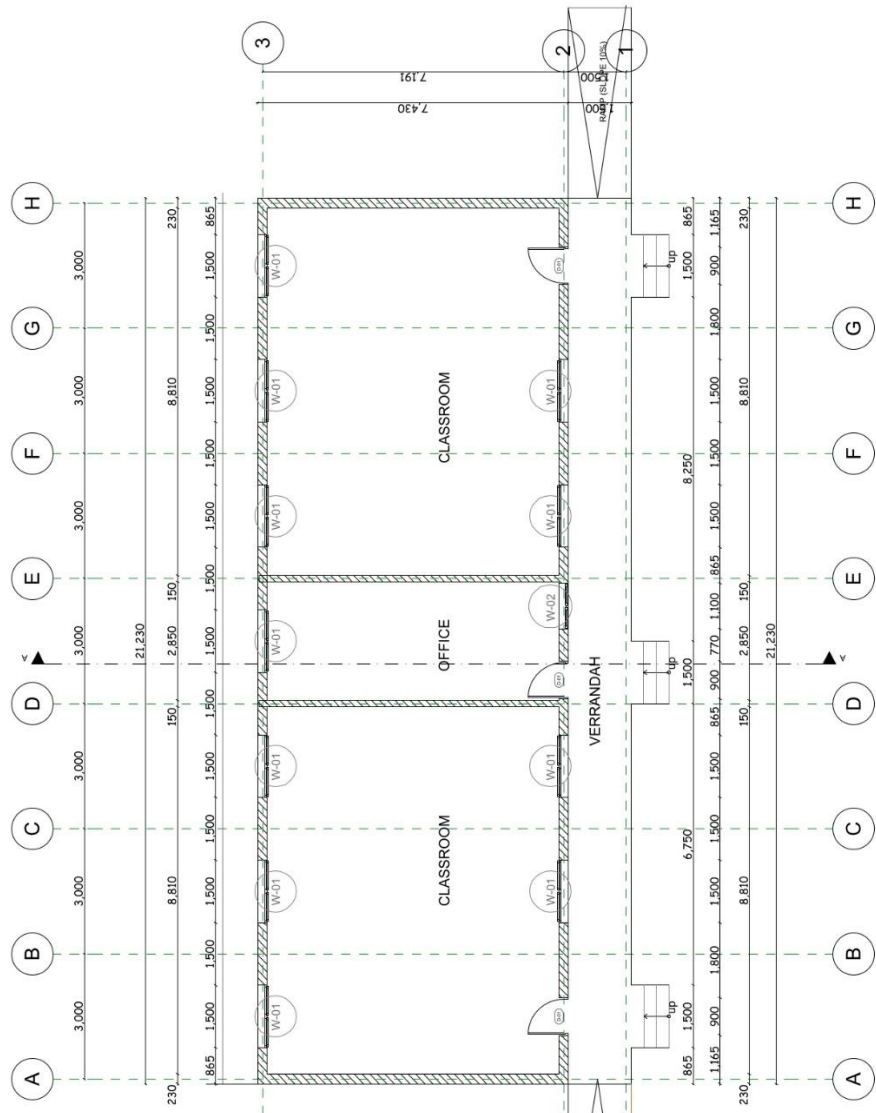

TOTAL FLOOR AREA = 189.6 SQM

MINISTRY OF EDUCATION, SCIENCE AND TECHNOLOGY IN COLLABORATION WITH PRESIDENT'S OFFICE REGIONAL ADMINISTRATION AND LOCAL GOVERNMENT	PROVISION OF PHYSICAL FACILITIES IN SECONDARY SCHOOLS FOR SECONDARY EDUCATION QUALITY IMPROVEMENT PROGRAM	DRAWING TITLE: 2-CLASSROOMS BLOCK WITH OFFICE GABLE	
		Date: June 2023	Scale: To fit
		Drawn by: JAS	Checked by: JR

NOTE:

- All dimensions are in millimetres unless otherwise stated. In case of discrepancy, consult the Structural Engineer.
- Structural engineering drawings should be read in conjunction with relevant architectural drawings.
- All reinforced concrete shall be Grade C25.
- Cube strength not less than 20N/mm² at 28 days.
- Steel for reinforced concrete shall conform with BS-4449 whereby $f_y = 460\text{N/mm}^2$.
- Bars lap length should be at least 50 times the diameter of the bars lapped. Splicing should be done as per IS 456 with copies of the manufacturers certificates of tests for the steel reinforcement to be used.
- Reinforcement shall comply with BS12 and shall be "Ordinary Portland Cement".
- Clear cover for reinforcement shall be as follows:
 - Slabs 25mm
 - Beams 25mm
 - Columns 25mm
- All concrete work to be done in one operation.
- All steel fixing, shuttering and formwork shall be done under close supervision of Structural Engineer.
- Sand borrow pits shall be clean and free from organic materials and shall be approved by Structural Engineers before use.
- Minimum Compressive Strength for Blocks shall be 3.5N/mm².

PROJECT:
 PROPOSED STANDARD DRAWINGS
 FOR SECONDARY EDUCATION
 QUALITY IMPROVEMENT PROGRAM

MINISTRY OF EDUCATION,
 SCIENCE AND TECHNOLOGY
IN COLLABORATION WITH
 PRESIDENT'S OFFICE
 REGIONAL ADMINISTRATION AND
 LOCAL GOVERNMENT.

Designed by: Eng. J.M.S
 Checked by: Eng. R.A.I.M
 Approved by:

DRAWING TITLE:
 PROPOSED TWO - CLASSROOMS
 WITH OFFICE BLOCK
 FOUNDATION LAYOUT PLAN
 (REVISED - 1)

DRAWING USE:
 For Building permit:
 For Construction:

Drawn by: J.M.S
 Date: June 2023
 Drawing No:STR.CR
 Sheet: 01/07

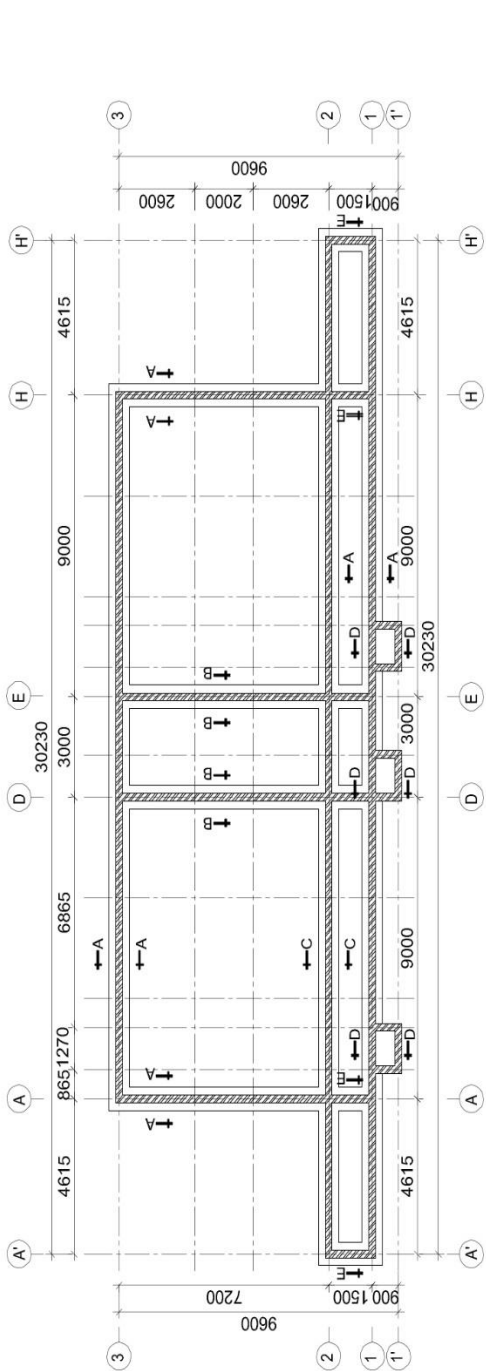

FOUNDATION LAYOUT PLAN
 Scale 1:100

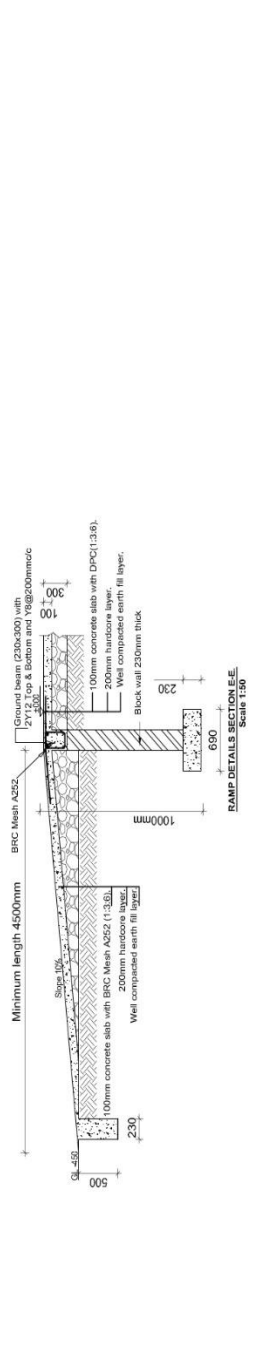
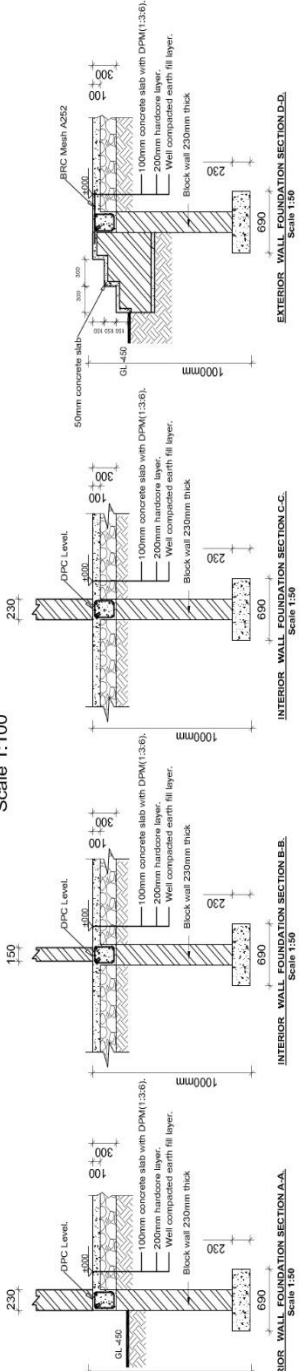

RAMP DETAILS SECTION E.E
 Scale 1:50

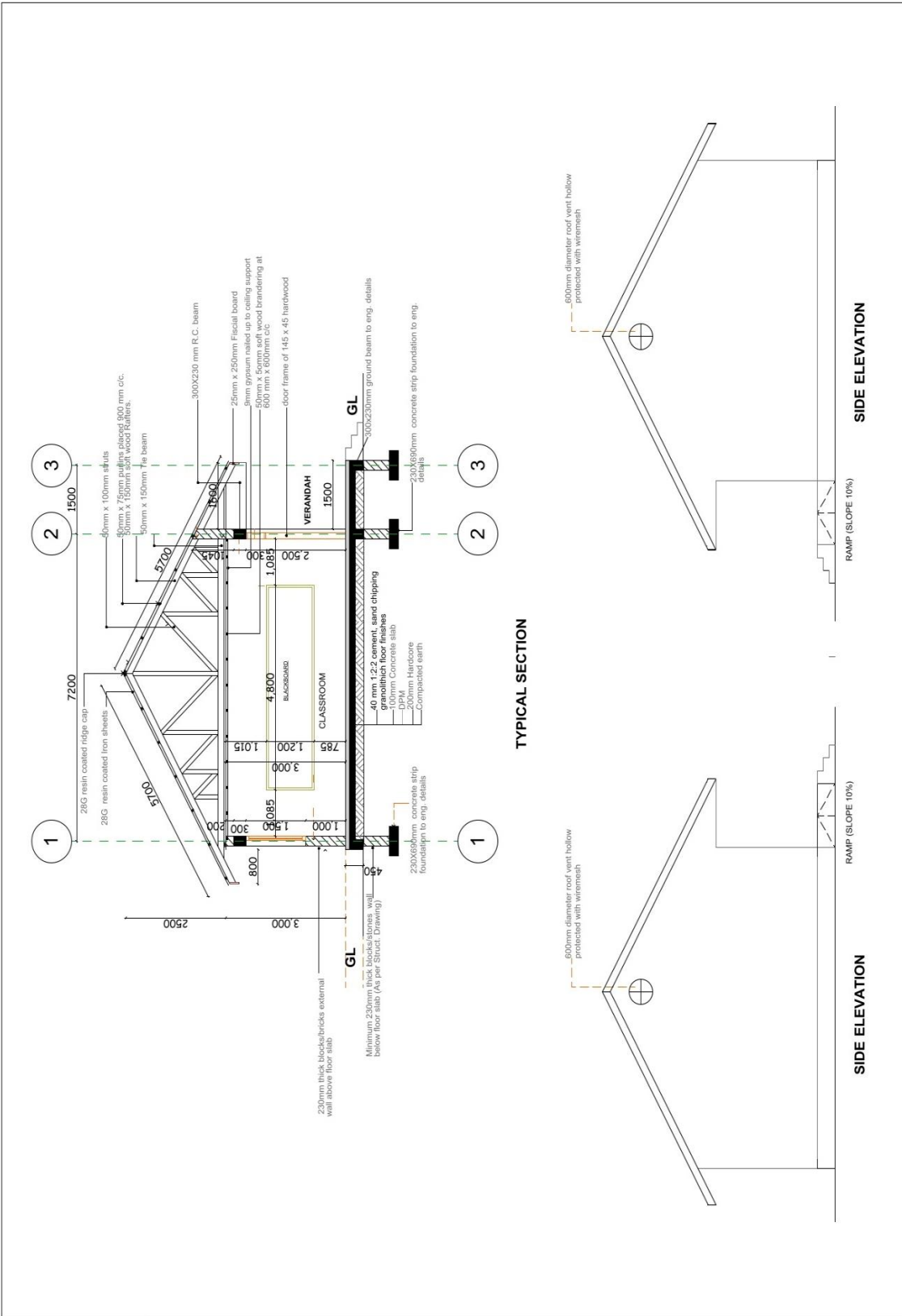

MINISTRY OF EDUCATION, SCIENCE AND TECHNOLOGY <i>IN COLLABORATION WITH</i> PRESIDENT'S OFFICE REGIONAL ADMINISTRATION AND LOCAL GOVERNMENT	PROVISION OF PHYSICAL FACILITIES IN SECONDARY SCHOOLS FOR SECONDARY EDUCATION QUALITY IMPROVEMENT PROGRAM	DRAWING TITLE: 2- CLASSROOMS BLOCK WITH OFFICE GABLE TYPICAL SECTION - SIDE ELEVATIONS DRAWING NO: ARC/3CRGO/03	Date	June, 2023
			Drawn by	IAS
			Checked by	JR
			Scale	To fit

NOTE:

- All dimensions are in millimetres unless otherwise stated. In case of discrepancy, consult the Structural Engineer.
- All structural engineering drawings should be read in conjunction with relevant architectural drawings.
- All reinforced concrete shall be Grade C30/37 with a minimum compressive strength not less than 20N/mm² at 28 days.
- Steel for reinforced concrete shall conform to BS4449 whereby $f_y = 460N/mm^2$.
- Bars lap length should be at least 50 times the diameter of the bars lap joint.
- Reinforcement shall be provided with copies of the manufacturers certificates of tests for the steel reinforcement to be used.
- Reinforcement shall comply with BS12 and shall be "Ordinary Portland Cement".
- Clear cover for reinforcement shall be as follows:
 - Slabs 25mm
 - Beams 25mm
 - Columns 25mm
- All concrete work to be done in one operation.
- All steel fixing, shoring and bracing shall be done under the close supervision of Structural Engineer.
- Sand borrow pits shall be clean and free from organic materials and shall be approved by Structural Engineers before use.
- Minimum Compressive Strength for Blocks shall be 3.5N/mm².

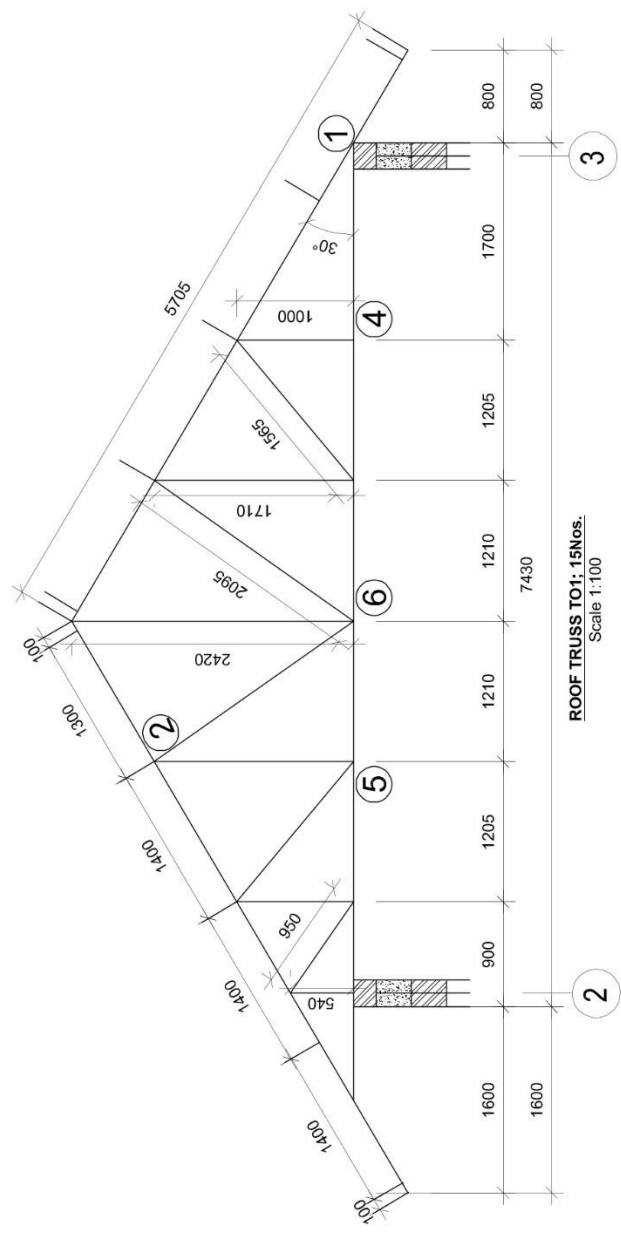

PROJECT:
 PROPOSED STANDARD DRAWINGS
 FOR SECONDARY EDUCATION
 QUALITY IMPROVEMENT PROGRAM

MINISTRY OF EDUCATION,
 SCIENCE AND TECHNOLOGY
IN COLLABORATION WITH
 PRESIDENT'S OFFICE
 REGIONAL ADMINISTRATION AND
 LOCAL GOVERNMENT.

Designed by: Eng. J.M.S
 Checked by: Eng. R.A.M
 Approved by:

DRAWING TITLE:
 PROPOSED TWO - CLASSROOMS
 WITH OFFICE BLOCK
 ROOF TRUSS DETAILS
 (REVISED - 1)

DRAWING USE:
 For Building permit:
 For Construction:

Drawn by: J.M.S
 Date: June 2023
 Drawing No:STR.CR
 Sheet: 05/07

Placenta pit

Layout for health center and dispensary

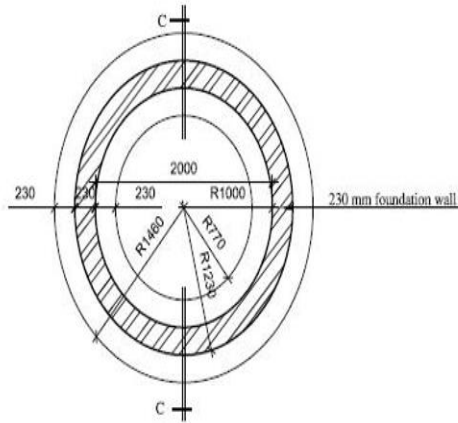

1 PLACENTA PIT - FOUNDATION PLAN
AS/001 1:40

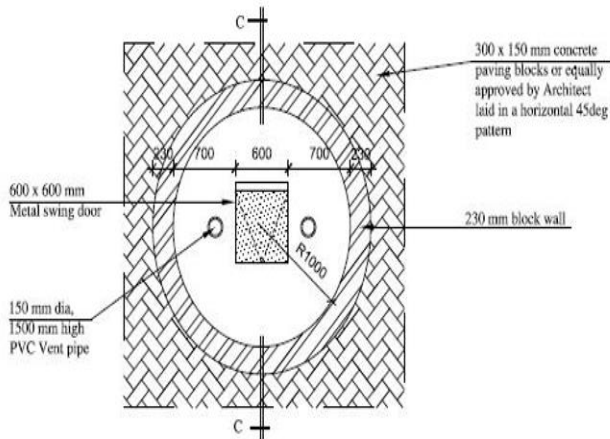

2 PLACENTA PIT - FLOOR PLAN
AS/001 1:40

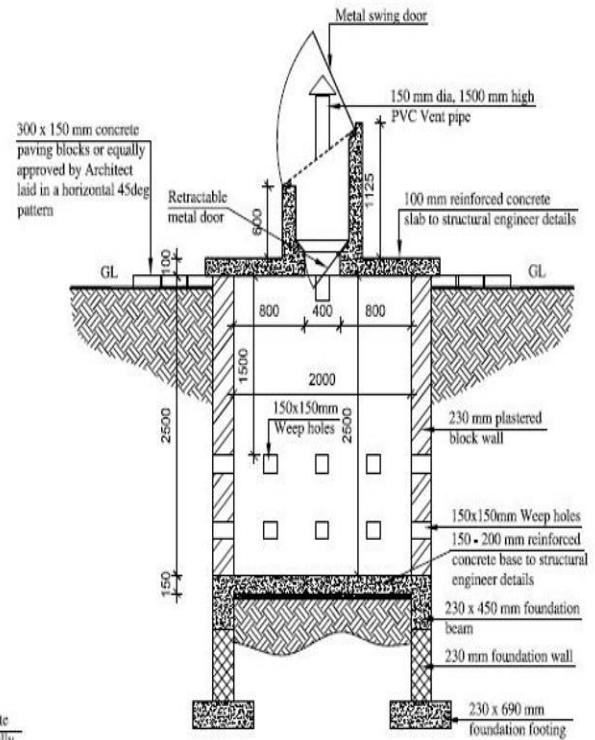

3 PLACENTA PIT - SECTION A-A
AS/001 1:40

NOTE:

1. Recommended for use by hospitals/health centers/dispensaries producing placentas.
2. The unit must be constructed by skilled technician who has been trained on how to manage the inner structure of the unit to facilitate soak away process and decomposition.
3. It must be provided with vent pipe - one opening pipe for air inlet and the second pipe for air outlet.
4. Location of structure to be positioned in location to the wind direction
5. Do not throw plastics inside the pit

Ash pit

Layout for ash pit

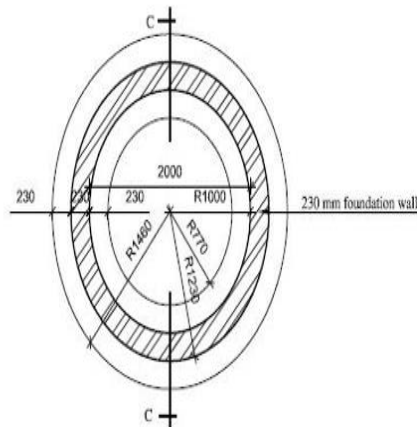

1 ASHPIT - FOUNDATION PLAN
AS/001 1:40

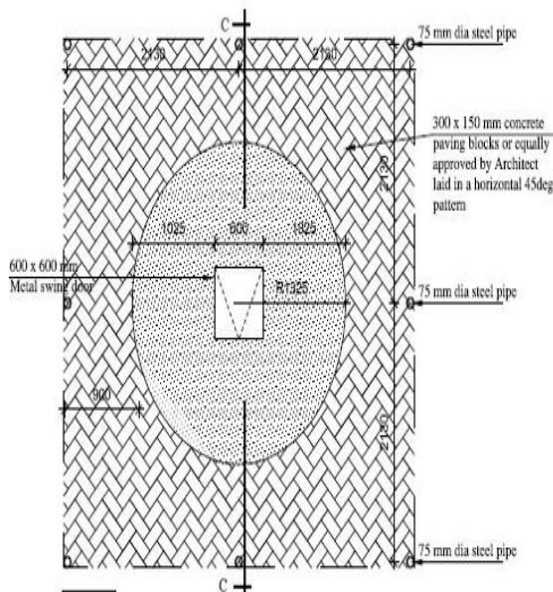

2 ASHPIT - FLOOR PLAN
AS/001 1:40

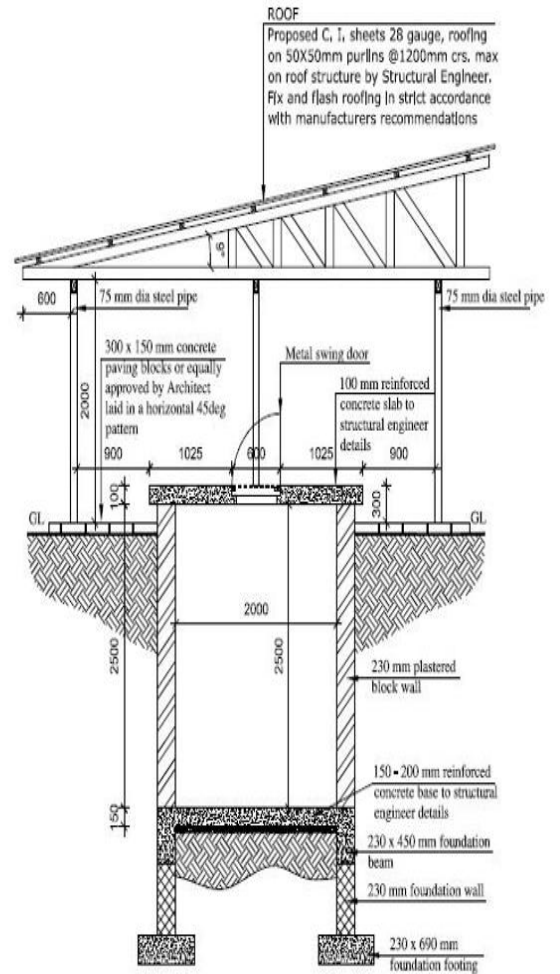

3 ASHPIT - SECTION A-A
AS/001 1:40

	Diameter (m)	Height (m)	Diameter (m)	Height (m)	Diameter (m)	Height (m)
Capacity	2.0	2.5	2.0	3.0	2.5	3.5
Volume	7,857.15 litres		9,428.50 litres		17,187.50 litres	
Designation	Dispensaries & health centers		District hospitals		Regional hospitals	

NOTE:

Ashpit size will vary depending on the ash production per day, refers to the table above.

ANNEXES

Annex 1: Layout for De Mont fort Incinerator Mark III

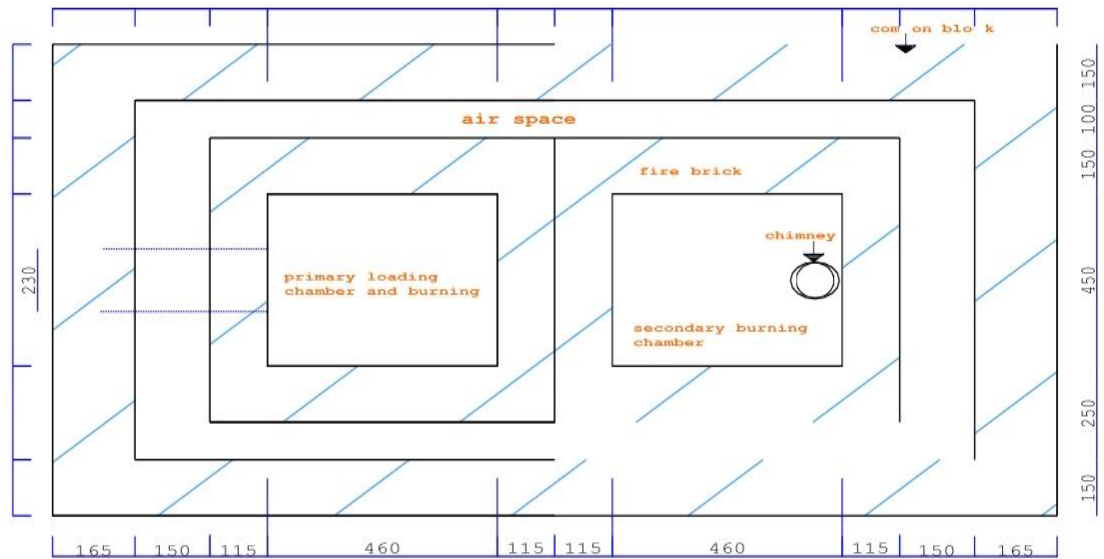

FLOOR PLAN

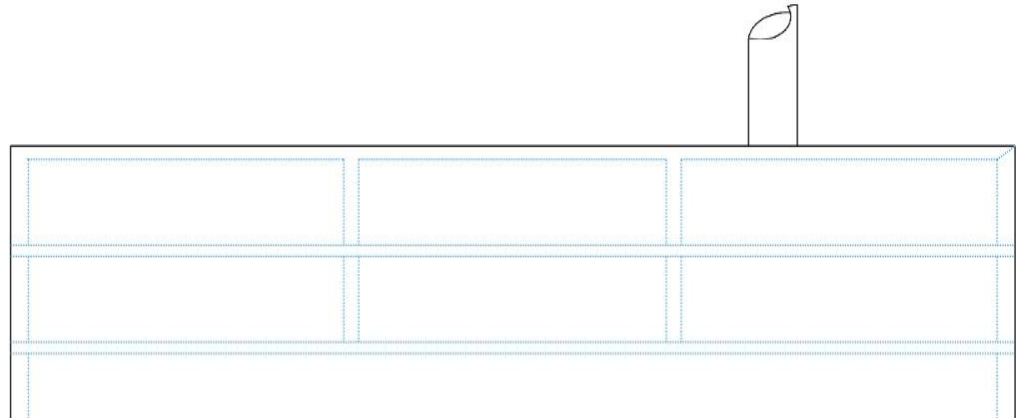

Floor plan:

- Showing primary and secondary burning chambers.
- Showing plan for the chimney installation.
- Showing facility floor measurements.

SECTION VIII: BILL OF QUANTITIES

RENOVATION 6 CLASSROOMS & 3 OFFICE ROOMS

S/N	ITEM DESCRIPTIONS	QTY	UNIT	RATE	AMOUNT
	SECTION NR.01				
	Supply and fix the following aluminium windows 2mm thick frame with 5mm thick,mosquito gauze, iron mongeries and all necessary accessories: including assembling, screwing to sub - framesurrounds, pointing externally with mastic, stripping off protective tape from aluminium frames				
	overall size 900 x 1500mm high	14	nr		
	overall size 1200 x 1500mm high	1	nr		
	overall size 1500 x 1500mm high	1	nr		
	overall size 1500 x 1260mm high	11	nr		
	overall size 800 x 1200mm high	4	nr		
	overall size 1500 x 1200mm high	11	nr		
	overall size 1470 x 1200mm high	1	nr		
	Panelled Hardwood Selected (mninga, mkongo or mkola)				
	Panelled doors; 120 x 45mm top rails and stiles; 175 x 45mm bottom rails; 120 x 45mm intermediater rails; two panels infilled with 95x45mm tongued, grooved and jointed on side vertical boarding				
B	Single leaf door type ;				
	overall size 850 x 2180mm high	3	Nr		
	overall size 850 x 1900mm high	4	Nr		
	overall size 960 x 2100mm high	3	Nr		
	Frames, sills and kerb; all are hardwood (Door frames)				
	Supply and fix (50 x 150)mm frame complete with one labour - overall size 900 x 2500mm high	1	Nr		
	IRON MONGERY				
	Supplying and fixing iron mongery to UNION context catalogue				
C	Mortise lock; Three lever sets cat. No. 2243 with rebate component model 2979	10	Nr		
D	Butt hinges; 100mm Brass	15	Nr		
	TO COLLECTION				

DISTRICT ENGINEER (WORKS)
BAHI DISTRICT COUNCIL
P. O. BOX 2993
MORDITA

S/N	ITEM DESCRIPTIONS	QTY	UNIT	RATE	AMOUNT
	FLOOR FINISHES				
	BEDS In-situ finishings; cement and sand; screeded bed sand backings; Mix ratio (1:3)				
E	32mm thick beds, steel floated to a smooth floors finish;	437	Sm		
	Ceilling finishings				
	Plain sheet finishings; Gypsum board ceiling, 9mm thick; butt joints with joints sealed with and including fibre tape fixed with approved adhesive				
A	To ceilings; to timber base; fixing with approved screws; Internally	437	Sm		
B	Ceilling cornice	250	M		
	Structrural timbers; softwood pressure impregnated with preservatives				
C	50 x 75mm brandering.	390	M		
D	15mm thick plastering for plinth rectification	85	M2		
	PAINTING EXTERNAL & internal WALLS				
	Painting; external work; three coats of Acrylic Based Weather Guard; plastered surface				
E	Walls; over 300mm girth	900	Sm		
	CEILING Painting; internal work; three coats of Matt Emulsion; wood surface				
F	Ceiling; over 300mm girth; Internally	437	Sm		
G	25 x 250mm fascia boards	145	m		
	TO COLLECTION				
	PG 3/2/2				
	PG 3/2/3				
SECTION NO.1 RENOVATION WORKS					

DISTRICT ENGINEER (WORKS)
BAHI DISTRICT COUNCIL
P. O. BOX 2993
DODDHA

SUMMARY

DISTRICT ENGINEER (WORKS)
BAHI DISTRICT COUNCIL
P. O. BOX 2993
DODDHA

TOTAL COLLECTION

VAT (18%)

TOTAL RENOVATION OF 6 CLASSROOMS AND 3 OFFICE ROOMS

PROPOSED COMPLETION FOR CONSTRUCTION OF MKAKATIKA DISPENSARY

BILL No. 01 MAIN BUILDING

Item	Description	Unit	Qty	Rate	Amount
	ELEMENT No. 01: DOORS				
	General Joinery				
	Hardwood Mninga/ Mkongo				
	Pannelled Doors				
	45mm thick pannelled doors comprising of 45 x 100mm rebated stiles, all panels filled in with and including 25mm thick hardwood boards				
a	900mm x 2100mm high overall size	No	8		
	Ironmongery; supply and fix the following as manufactured by Union ltd."or other equal and approved to hardwood with matching screws"				
b	100mm Brass butt hinges.	Pairs	11.0		
c	3 Lever Mortice lock - ref: union	Nr.	11		
d	2 Lever Mortice lock for Toilets	Nr.	3		
	Clear glass				
	5mm thick clear glass sheet; glazed with 25 X 25mm hardwood beads:				
i	Glass panes over 0.1m ² not exceeding 0.5m ² including beads	m ²	4		
	ELEMENT No. 01: DOORS TOTAL CARRIED TO SUMMARY OF BILL No. 01				

DISTRICT ENGINEER (KEMERAS)
BAHI DISTRICT BUREAU
P. O. BOX 4993
KABITA

	ELEMENT No. 02: FINISHINGS				
	Insitu finishings				
	<u>Graniti GN 572 Mid Grey Non slippery porcelain tiles "high quality" bedding in premixed thin set cement mortar and grouting with coloured sandless tile grout</u>				
	400x400mm; 4mm diagonally joints ways; to floors to level; to cement and sand base				
c	Floors	m ²	12		
e	120mm Thick skirting	m	15		
	Cement and sand (1:4) wood floated surface finish				
f	32mm Bed to receive floor tiles	m ²	12		
	250x400mm; 4mm diagonally joints ways; to walls; to cement and sand base				
j	walls	m ²	22.5		
	ELEMENT No. 02: FINISHING TOTAL CARRIED TO SUMMARY OF BILL No. 01				
	ELEMENT No. 03: PAINTING AND DECORATIONS				
	Internal works				
	<u>Prepare and apply one thinned coat and two full coats of wash 'n' ware paint</u>				
a	Plastered walls	m ²	26		
	<u>Varnishing; internal work; prepare and apply three coats of clear polyurethane clear varnish; wood surfaces.</u>				
d	General surfaces over 300mm girth	m ²	50		
e	Frames, linings and associated mouldings.	m	70		
	ELEMENT No. 03: PAINTING AND DECORATION TOTAL CARRIED TO SUMMARY OF BILL No. 01				

DISTRICT ENGINEER (MUNICIPALITY)
 BAHU DISTRICT - MUMBAI
 P. O. DO X 4993
 MUMBAI

	ELEMENT No. 04:ELECTRICAL INSTALLATIONS				
	DISTRIBUTION SYSTEM				
a	6Ways TPN distribution board with RCCB incomer and outgoing MCBs as shown in Schematic diagram as ABB or approved equal.	No	1		
	POWER POINTS				
b	2 x 13A Double switch socket as ABB or HAGER or TRONIC make	No	12		
	LIGHT FITTINGS, FANS AND SWITCHES				
c	Lamp holder straight as manufactured by Tronic or Equal approved complete with 15W bulbs	No	15		
c	Lamp holder angle as manufactured by Tronic or Equal approved complete with 15W bulbs	No	12		
d	10A 1 gang 1 way flush light switch c/w steel box as ABB or HAGER or LEGRAND make	No	7		
d	10A 1 gang 2 way flush light switch c/w steel box as ABB or HAGER or LEGRAND make	No	6		
	CABLES NB: Cables for 1.5sqmm 2.5sqmm and 4sqmm should be EURO or other equal approved				
e	1C x 1.5mm ² PVC copper cable				
	(i) Red	Roll	2		
	(ii) Black	Roll	2		
	(iii) Green	Roll	2		
f	1C x 2.5mm ² PVC copper cable				
	(i) Red	Roll	1		
	(ii) Black	Roll	1		
	(iii) Green	Roll	1		
	FIXED ENCLOSURES FOR CABLE RUNS				
h	metal box single	Pcs	8		
i	Box twin metal	Pcs	10		
l	Earth rod approved copper 16mm not less than 1200mm	No.	1		
m	Insulation tape	No	2		
o	Round cover	No	16		

DISTRICT ENGINEER (WORKS)
BAHI DISTRICT, JHARKHAND
P. O. DO X 2993
MOBINA

	Gate valve 1/2"	Pcs	3		
	Thread tape	Pcs	10		
	Male socket 1/2"	Pcs	3		
	PVC pipe 1 1/4"	m	4		
	PVC Pipe Class B 4"	Pcs	3		
	PVC elbow 4"	Pcs	2		
	P- trap 4"	Pcs	1		
	Vent clamp 4"	Pcs	4		
	Vent Cap 4"	Pcs	2		
	Polly pipe 3/4"	m	15		
	Polly Tee 3/4"	Pcs	9		
	Male Connector 3/4" HDPE	Pcs	3		
	Tee connector 3/4" HDPE	3	pc		
	Taps with 6" Levers operating for elbow control and its accessories	pc	10		
	sunwa cock	2	PCS		
	Angle valve	4	PC'S		
	PVC tee 1 1/2"	2	PC'S		
	PVC tee 1 1/4"	2	PC'S		
	PVC bend 1 1/4"	2	PC'S		
	PVC bend 1 1/2"	2	PC'S		
	PVC bend with inspection eye 4"	1	PC'S		
	PVC bend 4"	1	PC'S		
	PVC plug 1 1/4"	2	PC'S		
	PVC plug 1 1/2"	2	PC'S		
	PVC socket with female thread 1 1/4"	2	PC'S		
	PVC socket with female thread 1 1/2"	2	PC'S		
	Non-trap 1 1/2"	6	PC'S		
	Tangit	1	TIN		
	Shower rose	1	PC'S		
	Flexible pipe;	6	PC'S		
	Fisherbolt (za kufungia masink)	10	pair		
	Bomba za chuma 1/2" (Kushikiza masink)	6	m		
	stop cock pex 3/4"	2	PC'S		
	stop cock pex 1/2"	1	PC'S		
	MANHOLES:				
	DRAINAGE				
k	Excavate trench to receive pipes; commencing at ground level; not exceeding 1.5m. deep; average 1000mm. deep; including grading bottom; backfilling and compacting and removal of surplus excavated material.	Item	2		
	To Collection				
	COLLECTION				
	Page 01/10.1				

DISTRICT ENGINEER (WORKS)
BAHI DISTRICT COUNCIL
P. O. BOX 4993
MOMBASA

Page 01/10.2				
Page 01/10.3				
ELEMENT No. 05: PLUMBING & SANITARY INSTALLATION-Provisional TOTAL CARRIED TO SUMMARY OF BILL No. 01				
Summary:				
ELEMENT NO. 01- DOORS				
ELEMENT NO. 02 - FINISHINGS				
ELEMENT NO. 03 - PAINTING AND DECORATIONS				
ELEMENT NO. 04: ELECTRICAL INSTALLATION				
ELEMENT NO. 05: PLUMBING & SANITARY INSTALLATION				
BILL No. 01 FOR COMPLETION OF MKAKATIKA DISPENSARY				

DISTRICT ENGINEER KAMPALA
BAHI DISTRICT - KIGALI
P. O. BOX 2993
000111

PROPOSED CONSTRUCTION OF INCINERATOR, ASH PIT & PLACENTA PIT					
BILL No. 01 INCINERATOR, ASH PIT & PLACENTA PIT					
Item	Description	Unit	Qty	Rate	Amount
A	EXCAVATIONS AND EARTHWORK				
	Excavate oversite to remove top soil average 150mm thick and remove from site	m ²	32		
B	Excavate pits commencing at reduced level and not exceeding 1*30 metres deep	m ³	45		
C	Extra over excavaation for excavating in hard rock as described	m ³	1		
E	Backfilling around foundation	item	1		
G	Provide all necessary planking and strutting to faces of excavations as described	item	1		
	HARDCORE				
A	150mm bed hardcore laid and consolidated as described	m ²	3		
	CONCRETE WORK				
	<u>Vibrated Insitu concrete reinforced with high tensile bars completed with formwork</u>				
	<u>Reinforced concrete grade 20 as described</u>				
b	Foundations	m ³	1.5		
c	150mm bed laid level	m ²	5		
	<u>Reinforced concrete grade 25 as described</u>				
c	100mm top slab laid to level	m ²	4		
	Steel fabric reinforcement				
d	Conforce' reference 237 or other equal and approved fabric reinforcement with 130mm side and end laps	Kg	210		
	Sawn formwork to reinforced concrete to produced a smooth finish as described				
e	To 100mm vertical edge of bed	m	15		
f	To soffits of suspended slabs	m ²	15		

DISTRICT ENGINEER (MUNICIPAL)
 BAHU DISTRICT, BHUBANESHWAR
 P. O. NO. 1993
 BHUBANESHWAR

BRICKWORK AND BLOCKWORK			
	Precast concrete blocks type A lid for substructure		
	Double Solid burnt brick walling, bedded and jointed with cement mortar (1:4). Including fire brick lining		
A	230mm wall (Cement sand block 6")	m ²	50
B	Fire bricks (230 x 115 x 75)mm	m ²	5
	Finishings		
F	15mm thick cement sand (1:3) plaster to concrete block wall	m ²	32
	Painting and Decorating		
G	Prepare and apply three coats of black bituminous paint on plastered plinth exceeding 20mm	m ²	15
	ROOFING		
	IBR chromadek steel roofing sheets with approved end side lapping, fixed in accordance with manufacturer's recommendations as described		
A	Roof sheets fixed to 75 x 50mm soft wood purlins (measured separately) by 4' roof nails	m ²	14
B	100mm x 50mm softwood rafter/tie beam fixed to tubular steel column bolted on angle cleats	m	60
C	75mm x 50mm softwood purlins fixed to tubular steel column bolted on angle cleats	m	15
	STEEL WORK		
	Supply and install steel as per manufacturer instructions or equal and approved; rived with two coats of red oxide before delivery to site (the works include supply, cut to size, joining in appropriate position and fix into position as required)		
A	4mm thick flat bars	pcs	2
b	4mm stanless steel sheet	sheet	0.5
c	Chimney pipe(stainless), 6 inches diameter 3-4mm including chimney cover	pcs	1
d	Angle line 3"x2" for frame, reinforced cover sheet, outer and inner wall tighting 2.5inches- 2.5 mm thickness	pcs	3
e	Air vent pipe - squire pipe 2.5cm 2mm thick	pcs	1

DISTRICT ENGINEER (CIVIL)
 BAHU DISTRICT, JALPAIGURI
 P. O. BOX 6993
 HOORHA

f	16mm size diameter iron bar for inner wall	pcs	1		
g	Hinges Strong enough 1 inches	pcs	2		
h	Iron bar for grate 16mm	pcs	0.5		
i	U- channel 4mm thick-2x3 inches	pcs	0.5		
j	piece round pipe for L/door(2 piece 1 inches size	pcs	1		
k	Bolts and nuts 14 mm size	pcs	20		
l	FENCE				
	The Fence shall include fencing wire, 50mm diameter black pipe poles, three rows straining wires, installed to concrete strip	m	30		
	Top hung metal door angle frame with 600 x 450mm opening complete with pad lock, handle etc	nr	1		
	6mm thick metal sleeve built into brickwork	item	1		
	60 x 60mm angle bars	nr	2		
	15.2mm dia. Fire bars at 50mm c/c 3 nr. Cross pieces welded on and fitted loose on brickwork projection	kg	7		
	Paving blocks	m ²	25		
	FINISHINGS				
	Prepare and apply one undercoat and three coats of PVA emulsion described				
B	Plastered walls	m ²	14		
	Touch up primer and apply one under coat three coats gloss oil paint as described on				
C	Small diameter steel pipes and steel door	m ²	2.5		
D	General surfaces of s/w fascia boards	m ²	3.5		
	3 days On site training				
	SUB TOTAL				
	VAT 18%				
	GRAND TOTAL TO MEASURED WORKS				-

DISTRICT ENGINEER (M/R&S)
BAHI DISTRICT JUBAILI
P. O. BOX 8993
JUBAILI

SECTION IX: FORMS OF TENDER

1. Form of Contract Agreement

This Agreement, made the [----] day of [-----], [2021] between [Good Neighbors Tanzania] (hereinafter called "the Employer") and [-----] (hereinafter called "the Contractor") of the other part.

Whereas the Employer is desirous that the Contractor execute [*name and identification number of contract*] (hereinafter called "the Works") and the Employer has accepted the Tender by the Contractor for the execution and completion of such works and the remedying of any defects therein in the sum of [*contract price in words and figures*] (hereinafter called "Contract Price").

Now this Agreement witnessed as follows:

1. In this Agreement, words and expressions shall have the same meanings as are respectively assigned to them in the Conditions of Contract hereinafter referred to, and they shall be deemed to form and be read and construed as part of this Agreement.
2. In consideration of the payments to be made by the Employer to the Contractor as hereinafter mentioned, the Contractor hereby covenants with the Employer to execute and complete the Works and remedy any defects therein in conformity in all respects with the provisions of the Contract.
3. the Employer hereby covenants to pay the Contractor in consideration of the execution and completion of the Works and the remedying of defects wherein the Contract Price or such other sum as may become payable under the provisions of the Contract at the times and in the manner prescribed by the Contract.

In Witness whereof the parties thereto have caused this Agreement to be executed the day and year first before written.

The Common Seal of _____
Was hereunto affixed in the presence of: _____

Signed, Sealed, and Delivered by the said _____
In the presence of: _____

Binding Signature of Employer _____
Binding Signature of Contractor _____

2. Form of Tender

[date]

To: [name and address of Employer]

We [insert name of tenderer], offer to execute the [name and identification number of contract] in accordance with the Conditions of Contract accompanying this tender for the Contract Price of [amount in numbers], [amount in words] [name of currency].

The Contract shall be paid in the following currencies:

Currency	Percentage payable in currency	Rate of exchange: one foreign equals [insert local]	Inputs for which foreign currency is required
(a)			
(b)			

The advance payment required is:-

Amount	Currency
(a)	
(b)	

We declare that our tendering price did not involve agreements with other tenderers for the purpose of tender suppression.

We hereby confirming [insert name of the appointing authority] to be the appointing authority, to appoint the adjudicator in case of any arisen disputes in accordance with ITT 43.1[Adjudicator]

We are not participating, as tenders, in more than one tender in this tendering process other than alternative tenders in accordance with the tendering documents.

We declare that, as tenderer (s) we do not have conflict of interest with reference to ITT 3.7 [Eligibility of Tenderers]

With reference to ITT 3.11, it is our intention to subcontract approximately [insert the percent] percentage of the Tender /Contract Price, details of which are provided herein.

Our firm, its affiliates or subsidiaries, including any subcontractors or suppliers for any part of the contract has not been declared ineligible by the Government of the United Republic of Tanzania under Tanzania's laws or any other official regulations.

We declare that our tendering price did not involve agreement with other tenderers for the purpose of tender suppression.

This tender and your written acceptance of it shall constitute a binding Contract between us.

We understand that you are not bound to accept the lowest or any tender you receive.

We hereby confirm that this tender complies with the tender validity and tender security required by the tendering documents and specified in the Tender Data Sheet.

Authorized Signature: _____

Name and Title of Signatory: _____

Name of Tenderer: _____

Address: _____

3. Standard Power of Attorney

TO ALL IT MAY CONCERN

THAT BY THIS POWER OF ATTORNEY given on the *[insert date, month and year]*, WE the undersigned *[insert name of the company/donor]* of *[insert address of the company/donor]*, by virtue of authority conferred to us by the Board Resolution No of _day of *[insert year]*, do hereby ordain nominate and appoint *[insert name of donee]* of *[insert address of the donee]* to be our true lawful Attorney and Agent, with full power and authority, for us and in our names, and for our accounts and benefits, to do any, or all of the following acts, in the execution of tender No. *[insert tender number]* that is to say;

To act for the company and do any other thing or things incidental for *[insert tender Number]* of *[insert description of procurement]* for the *[insert name of the procuring entity]*;

AND provided always that this Power of Attorney shall not revoke or in any manner affect any future power of attorney given to any other person or persons for such other power or powers shall remain and be of the same force and affect as if this deed has not been executed.

AND we hereby undertake to ratify everything, which our Attorney or any substitute or substitutes or agent or agents appointed by him under this power on his behalf herein before contained shall do or purport to do in virtue of this Power of Attorney.

SEALED with the common seal of the said *[[insert name of the company]* and delivered in the presence of us this *[insert date]* day of *[insert month]* *[insert year]*.

IN WITNESS whereof we have signed this deed on this *[insert date]* day of *[insert month]* *[insert year]* at *[insert region]* for and on behalf of *[insert name of the company]*

.....

SEALED and DELIVERED by the
Common Seal of *[insert name of the donor/coy]*
This *[insert date, month and year]* }

DONOR BEFORE

ME:

COMMISSIONER FOR OATHS

4. Appendix to Tender

(i) Schedule of Adjustment Data

[In Tables A, B, and C, below, the Tenderer shall (a) indicate its amount of local currency payment, (b) indicate its proposed source and base values of indices for the different foreign currency elements of cost, (c) derive its proposed weightings for local and foreign currency payment, and (d) list the exchange rates used in the currency conversion. In the case of very large and/or complex works contracts, it may be necessary to specify several families of price adjustment formulae corresponding to the different works involved.]

Table A. Local Currency

Index code	Index description	Source of index	Base value and date	Tenderer's related currency amount	Range of weighting Proposed by the Procuring Entity	Tenderer's proposed weighting
	Non adjustable	—	—	—	a: _____* b: _____ to _____* c: _____ to _____* d: _____ to _____* e: _____ to _____* etc.	a: _____* b: _____ c: _____ d: _____ e: _____ etc.
Total						1.00

Table B. Foreign Currency

State type: [If the Tenderer wishes to quote in more than one foreign currency, this table should be repeated for each foreign currency.]

Index code	Index description	Source of index	Base value and date	Tenderer's related source currency in type/ amount	Equivalent in Foreign Currency 1	Range of weighting Proposed by the Procuring Entity	Tenderer's proposed weighting
	Non adjustable	-	-	-		a: _____* b: ----- to -----* c: ----- to -----* d: ----- to -----* e: ----- to -----* etc.	a: _____* b: _____ c: _____ d: _____ e: _____ etc.
Total							1.00

Table C. Summary of Payment Currencies

For[insert name of Section of the Works]

[Separate tables may be required if the various sections of the Works (or of the Bill of Quantities) will have substantially different foreign and local currency requirements. The Employer should insert the names of each Section of the Works.]

Name of payment currency	A Amount of currency	B Rate of exchange (local currency per unit of foreign)	C Local currency equivalent $C = A \times B$	D Percentage of Net Tender Price (NBP) $\frac{100 \times C}{NBP}$
--------------------------	-------------------------	--	--	---

Local currency _____		1.00		
Foreign currency #1 _____				
Foreign currency #2 _____				
Foreign currency # _____				
Net Tender Price				
Provisional sums expressed in local currency	*		*	
TENDER PRICE				

* To be entered by the Procuring Entity

Authorized Signature: _____

Name and Title of Signatory: _____

Name of Tenderer: _____

Address: _____

(ii) Qualification Information

Form of Qualification Information

To establish qualifications to perform the contract the Tenderer shall provide information requested in form

1. Individual Tenderers or Individual Member of Joint Ventures

1.1 Eligibility

Constitution or legal status of Tenderer: *[attach copy]*

Principal place of business: *[insert]*

Registration/ Certificate of Incorporation *[attach]*

CRB Certificate *[attach]*

Current Business License *[attach]*

Special Power of Attorney *[attach]*

Conflict of Interest - No conflict of interest in accordance with ITT 3.6 [should be declared in the Form of Tender]

Government-owned entity - meet conditions of ITT 3.8 [Attach legal status]

Experience

1.2 Work performed as prime Contractor on works of a similar nature and volume over the last 3 years.

S/No.	Project Name and Country	Name of Employer and full address	Contractor Participation	Type of Work Performed	Year	Value of Contract
1.						
2.						
3.						

To comply with this requirement, works cited should be at least 70 per cent complete.

Experience as prime contractor, sub-contractor in at least 3 Contracts for the past 3 years, each with a minimum value of TZS 80,000,000 that have been successfully and substantially completed and that are similar to the proposed works.

Also list details of work under way or committed, including expected completion dates.

S/No.	Name of Contract	Employer's Contact Address, Tel, Fax	Value of Outstanding Work [Current TZS Equivalent]	Estimated Completion Date	Average Monthly Invoicing Over Last Six Months [TZS/month]
1.					
2.					
3.					
n-1					
N					

1.3

Equipment and Plants

Major items of Contractor's Equipment proposed for carrying out the works. List all information requested below

List all information requested below

S/No.	Item of equipment	Description, make, and age (years)	Condition (new, good, Poor) and number available	Owned, leased (from whom?) or to be purchased (from whom?)
1.	Dump truck 7-10 tonnes			
2.	Water Bowser			
3.	Supervision Car-4WD pick up			
4.	Concrete mixer			
5.	Plate compactor			
n-1				

1.4**Personnel**

Qualifications and experience of key personnel proposed for administration and execution of the Contract. (CVs and Certificates of all key proposed key personnel shall be attached)

S/No	Position <i>[PE to list required key personnel]</i>	Name	Years of Experience (General Experience)	Years of experience in proposed position
1.	Civil Engineer		Minimum 3 years Experiences	
2.	Technician		Minimum 3 years Experiences	
3.	Site foremen		Minimum 5years	
4	Site foremen		Minimum 5years	
n-1				

REF:

1.5**Subcontracting**

Proposed sub-contractor and firms involved. Refer to ITT 3.11 and Clause 8 of General Conditions of Contract

S/No.	Sections of the Works	Value of subcontract	Subcontractor (name and address)	Experience in similar work
1.				
2.				
n-1				
n				

1.6**Average Annual Construction Turnover**

Minimum average annual construction turnover of TZS 200,000,000.00, calculated as total certified payments received for contracts in progress and/or completed within the last 5 years, divided by 5 years.

Annual turnover data (construction only)			
Year	Amount Currency	Exchange Rate	TZS Equivalent
Year 1			
Year 2			
Year 3			
Year 4			
Year 5			
		Average Annual Construction Turnover★	

★ Total TZS equivalent for all years divided by the number of years.

1.7 Financial Situation and Performance

Financial reports for the 5 years. Balance sheets, profit and loss statements, auditors' reports, etc.

[List below and attach copies.]

The submitted financial reports must demonstrate the current soundness of the Tenderer's financial position and indicate its prospective long-term profitability.

1. Average Coefficient of Current Ratio ≥ 1.1
2. Average Coefficient of Debt Ratio ≤ 0.75
3. Average Coefficient of Interest Coverage Ratio ≥ 5.0
4. Debt Equity Ratio ≤ 3.0

Information in this table should be extracted from the financial reports submitted.

Type of Financial information in (TZS)	Historic information for previous (TZS equivalent)				
	Year 1	Year 2	Year 3	Year 4	Year 5
Statement of Financial Position (Information from Balance Sheet)					
Total Assets (TA)					
Total Liabilities (TL)					
Total Equity/Net Worth (NW)					
Current Assets (CA)					
Current Liabilities (CL)					

Working Capital (WC)					
Information from Income Statement					
Total Revenue (TR)					
Profits Before Taxes (PBT)					
Cash Flow Information					
Cash Flow from Operating Activities					

NB: To fill financial information, you may consult your Accountant or Auditor.

1.8 Financial Capability

The Tenderer shall demonstrate that it has access to, or has available, liquid assets, unencumbered real assets, lines of credit, and other financial means (independent of any contractual advance payment) sufficient to meet the construction cash flow requirements estimated as per proposed Total BOQ sum for the subject contract(s) net of the Tenderers other commitments

Specify proposed sources of financing, such as liquid assets, unencumbered real assets, lines of credit, and other financial means, net of current commitments, available to meet the total construction cash flow demands of the subject contract or contracts.

Source of financing	Amount (TZS Equivalent)
1.	
2.	
3.	
4.	

1.9 Name, address, and telephone, telex, and facsimile numbers of banks that may provide references if contracted by the Employer.

1.10 Litigation History

Information on current litigation in which the Tenderer is involved.

S/No.	Other party(ies)	Cause of dispute	Amount involved
1.			
2.			

1.11 Occupation Health and Safety Policy

Information regarding Occupation Health and Safety Policy and Safety Record of the Tenderer

1.12 Proposed Work Programme

Proposed Program (work method and schedule). Descriptions, drawings, and charts, as necessary, to comply with the requirements of the tendering documents.

2. Joint Ventures

2.1 The information listed in 1.1 - 1.11 above shall be provided for each partner of the joint venture.

2.2 The information in 1.11 & 1.12 above shall be provided for the joint venture.

5. Letter of Acceptance

[letter head paper of the Employer]

[date]

To: *[name and address of the Contractor]*

This is to notify you that your tender dated [date] for execution of the [name of the Contract and identification number, as given in the Special Conditions of Contract] for the Contract Price of the equivalent of [amount in numbers and works] [name of currency], as corrected and modified in accordance with the Instructions to Tenderers is hereby accepted by us.

We hereby confirming [insert name of the Appointing Authority] to be the appointing authority, to appoint the Adjudicator in case of any arisen disputes in accordance with ITT 43.1.

You are hereby instructed to proceed with the execution of the said works in accordance with the Contract documents.

Please return the contract dully signed.

Authorized Signature: _____

Name and Title of Signatory: _____

Name of Agency: _____

Attachment: Form of Contract

SECTION X: FORMS OF SECURITIES

1. Tender Securing Declaration

Date: *[insert date (as day, month and year)]*

Tender No.: *[insert number of tendering process]*

Alternative No.: *[insert identification No if this is a Tender for an alternative]*

To: *[insert complete name of Procuring Entity]*

We, the undersigned, declare that:

We understand that, according to your conditions, tenders must be supported by a *[insert "Tender Securing Declaration" or "Tender Security" whichever was requested by Procuring Entity]*.

We accept that we will automatically be suspended from being eligible for tendering in any contract with the Procuring Entity for the period of time determined by the Authority, if we are in breach of our obligation(s) under the tender conditions, because we:

- (a) have withdrawn or modified our Tender during the period of tender validity specified in the Form of Tender;
- (b) disagreement to arithmetical correction made to the tender price; or
- (c) having been notified of the acceptance of our Tender by the Procuring Entity during the period of tender validity, (i) failure to sign the contract if required by Procuring Entity to do so or (ii) fail or refuse to furnish the Performance Security or to comply with any other condition precedent to signing the contract specified in the tendering documents.

We understand this *[insert "Tender Securing Declaration" or "Tender Security" whichever was requested by Procuring Entity]* shall expire if we are not the successful Tenderer, upon the earlier of (i) our receipt of your notification to us of the name of the successful Tenderer; or (ii) twenty-eight days after the expiration of our Tender.

Signed: *[insert signature of person whose name and capacity are shown]*

In the capacity of *[insert legal capacity of person signing the Tender Securing Declaration]*

Name: *[insert complete name of person signing the Tender Securing Declaration]*

Duly authorized to sign the tender for and on behalf of: *[insert complete name of Tenderer]*

Dated on _____ day of _____, _____ *[insert date of signing]*
Corporate Seal (where appropriate)

2. Performance Bank Guarantee [Unconditional]

[The **bank/successful tenderer** providing the Guarantee shall fill in this form in accordance with the instructions indicated in brackets, if the Employer requires this type of security.]

[insert bank's name, and address of issuing branch or office]

Beneficiary: *[insert name and address of Employer]*

Date: *[insert date]*

PERFORMANCE GUARANTEE No.: *[insert Performance Guarantee number]*

We have been informed that *[insert name of Contractor]* (hereinafter called "the Contractor") has been awarded a Contract No. *[Insert reference number of the Contract]* dated with you, for the execution of *[insert name of Contract and brief description of Works]* (hereinafter called "the Contract").

Furthermore, we understand that, according to the conditions of the Contract, a performance guarantee is required.

At the request of the Contractor, we *[insert name of Bank]* hereby irrevocably undertake to pay you any sum or sums not exceeding in total an amount of *[insert amount in figures]* (*[insert amount in words]*), such sum being payable in the types and proportions of currencies in which the Contract Price is payable, upon receipt by us of your first demand in writing accompanied by a written statement stating that the Contractor is in breach of its obligation(s) under the Contract, without your needing to prove or to show grounds for your demand or the sum specified therein.

This guarantee shall expire no later than twenty-eight days from the date of issuance of the Taking-Over Certificate, calculated based on a copy of such Certificate which shall be provided to us, or on the *[insert number day of [insert month], [insert year]*, whichever occurs first. Consequently, any demand for payment under this guarantee must be received by us at this office on or before that date.

[signature(s) of an authorized representative(s) of the Bank]

3. Performance Bond

By this Bond, *[insert name and address of Contractor]* as Principal (hereinafter called "the Contractor") and *[insert name, legal title, and address of surety, bonding company, or insurance company]* as Surety (hereinafter called "the Surety"), are held and firmly bound unto *[insert name and address of Employer]* as Oblige (hereinafter called "the Employer") in the amount of *[insert amount of Bond]* *[insert amount of Bond in words]*, for the payment of which sum well and truly to be made in the types and proportions of currencies in which the Contract Price is payable, the Contractor and the Surety bind themselves, their heirs, executors, administrators, successors, and assigns, jointly and severally, firmly by these presents.

Whereas the Contractor has entered into a Contract with the Employer dated the *[insert number]* day of *[insert month]*, *[insert year]* for *[insert name of Contract]* in accordance with the documents, plans, specifications, and amendments thereto, which to the extent herein provided for, are by reference made part hereof and are hereinafter referred to as the Contract.

Now, therefore, the Condition of this Obligation is such that, if the Contractor shall promptly and faithfully perform the said Contract (including any amendments thereto), then this obligation shall be null and void; otherwise it shall remain in full force and effect. Whenever the Contractor shall be, and declared by the Employer to be, in default under the Contract, the Employer having performed the Employer's obligations there under, the Surety may promptly remedy the default, or shall promptly:

- (1) complete the Contract in accordance with its terms and conditions; or
- (2) obtain a Tender(s) from qualified tenderers for submission to the Employer for completing the Contract in accordance with its terms and conditions, and upon determination by the Employer and the Surety of the lowest responsive Tenderer, arrange for a Contract between such Tenderer and Employer and make available as work progresses (even though there should be a default or a succession of defaults under the Contract or Contracts of completion arranged under this paragraph) sufficient funds to pay the cost of completion less the balance of the Contract Price; but not exceeding, including other costs and damages for which the Surety may be liable hereunder, the amount set forth in the first paragraph hereof. The term "Balance of the Contract Price," as used in this paragraph, shall mean the total amount payable by the Employer to the Contractor under the Contract, less the amount properly paid by the Employer to the Contractor; or

- (3) pay the Employer the amount required by the Employer to complete the Contract in accordance with its terms and conditions up to a total not exceeding the amount of this Bond.

The Surety shall not be liable for a greater sum than the specified penalty of this Bond.

Any suit under this Bond must be instituted before the expiration of one year from the date of issuance of the Certificate of Completion.

No right of action shall accrue on this Bond to or for the use of any person or corporation other than the Employer named herein or the heirs, executors, administrators, successors, and assigns of the Employer.

In testimony whereof, the Contractor has hereunto set its hand and affixed its seal, and the Surety has caused these presents to be sealed with its corporate seal duly attested by the signature of its legal representative, this *[insert day]* day of *[insert month]*, *[insert year]*.

Signed by *[insert signature(s) of authorized representative(s)]* on behalf of *[name of Contractor]* in the capacity of *[insert title(s)]*

In the presence of *[insert name and signature of witness]* Date *[insert date]*

Signed by *[insert signature(s) of authorized representative(s) of Surety]* on behalf of *[name of Surety]* in the capacity of *[insert title(s)]*

In the presence of *[insert name and signature of witness]* Date *[insert date]*

4. Bank Guarantee for Advance Payment

[Bank's Name, and Address of Issuing Branch or Office]

Beneficiary: _____ *[Name and Address of Employer]*

Date: _____

ADVANCE PAYMENT GUARANTEE No.: _____

We have been informed that *[name of Contractor]* (hereinafter called "the Contractor") has been awarded Contract No. *[reference number of the contract]* dated _____ with you, for the execution of *[name of contract and brief description of Works]* (hereinafter called "the Contract").

Furthermore, we understand that, according to the conditions of the Contract, an advance payment in the sum *[amount in figures]* (___) *[amount in words]* is to be made against an advance payment guarantee.

At the request of the Contractor, we *[name of Bank]* hereby irrevocably undertake to pay you any sum or sums not exceeding in total an amount of *[amount in figures]* (_____) *[amount in words]* upon receipt by us of your first demand in writing accompanied by a written statement stating that the Contractor is in breach of its obligation under the Contract because the Contractor used the advance payment for purposes other than the costs of mobilization in respect of the Works.

It is a condition for any claim and payment under this guarantee to be made that the advance payment referred to above must have been received by the Contractor on its account number _____ at _____ *[name and address of Bank]*.

The maximum amount of this guarantee shall be progressively reduced by the amount of the advance payment repaid by the Contractor as indicated in copies of interim statements or payment certificates which shall be presented to us. This guarantee shall expire, at the latest, upon our receipt of a copy of the interim payment certificate indicating that eighty (80) percent of the Contract Price has been certified for payment, or on the ___ day of ____, 2___, whichever is earlier. Consequently, any demand for payment under this guarantee must be received by us at this office on or before that date.

Yours truly,

Signature and seal: _____

Name of Bank/Financial Institution: _____

Address: _____

Date: _____

SECTION XI: INTEGRITY

Each Tenderer must submit a statement, as part of the tender documents, with either of the following format

MEMORANDUM (Format 1)

(Regulation 78(2) of the Public Procurement Regulations, 2013 - Government Notice No. 446 of 2013 as amended in 2016.)

This company _____ *[name of company]* places importance on competitive tendering taking place on a basis that is free, fair, competitive and not open to abuse. It is pleased to confirm that it will not offer or facilitate, directly or indirectly, any improper inducement or reward to any public officer their relations or business associates, in connection with its tender, or in the subsequent performance of the contract if it is successful.

This company has an Anti-Bribery Policy/ Code of Conduct and a Compliance Program which includes all reasonable steps necessary to assure that the No bribery commitment given in this statement will be complied with by its managers and employees, as well as by all third parties working with this company on the public sector projects, or contract including agents, consultants, consortium partners, sub- contractors and suppliers. Copies of our Anti-Bribery Policy/Code of Conduct and Compliance Program are attached.

Authorized Signature: _____

Name and Title of Signatory: _____

Name of Tenderer: _____

Address: _____

MEMORANDUM (Format 2)

(Regulation 78(2) of the Public Procurement Regulations, 2013 - Government Notice No. 446 of 2013 as amended in 2016.)

This company _____ *[name of company]* has issued, for the purposes of this tender, a Compliance Program copy attached -which includes all reasonable steps necessary to assure that the No-bribery commitment given in this statement will be complied with by its managers and employees, as well as by all third parties working with this company on the public sector projects or contract including agents, consultants, consortium partners, subcontractors and suppliers.

Authorized Signature: _____

Name and Title of Signatory: _____

Name of Tenderer: _____

Address: _____